

D

C

B

A

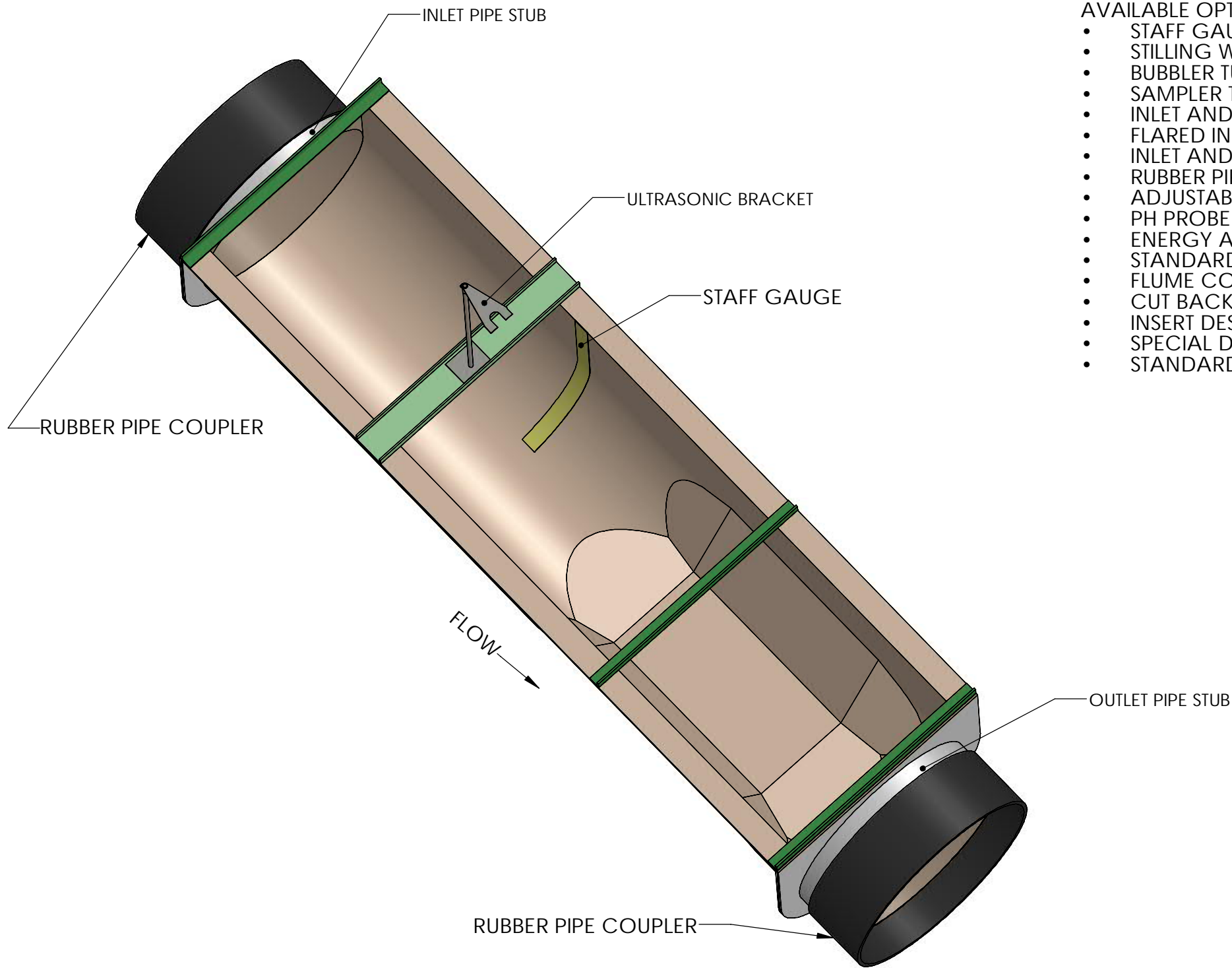

AVAILABLE OPTIONS:

- STAFF GAUGE (ENGLISH OR METRIC).
- STILLING WELL (INTEGRAL OR REMOTE).
- BUBBLER TUBE (SS 1/4" ID, INTEGRAL OR REMOVABLE).
- SAMPLER TUBE (SS 3/8" ID, INTEGRAL OR REMOVABLE).
- INLET AND OUTLET PIPE STUBS.
- FLARED INLET AND OUTLET TRANSITIONS PIPE STUBS.
- INLET AND OUTLET BULKHEADS.
- RUBBER PIPE COUPLERS W/ SS CLAMP BANDS.
- ADJUSTABLE SS ULTRASONIC BRACKET.
- PH PROBE CAVITY.
- ENERGY ABSORBING RACKS. (FIXED OR REMOVABLE).
- STANDARD OR SPECIAL DEPTHS (INCLUDING SURGE BOXES).
- FLUME COVERS (GRATING, FIBER SHEETING, CLEAR POLYCARBONATE).
- CUT BACK DESIGN.
- INSERT DESIGN.
- SPECIAL DESIGN (TO MEET SPECIAL PROJECT NEEDS).
- STANDARD COLOR IS BEIGE (CUSTOM COLORS AVAILABLE).

D

C

B

A

UNLESS OTHERWISE SPECIFIED:		NAME	DATE	 VPC FIBERGLASS 10478 Ridge Rd., Medina NY 14103 Toll Free: 888-290-9522 Phone: 585-735-9668	
DIMENSIONS ARE IN INCHES		DRAWN	LVR		10/5/2020
TOLERANCES:		CHECKED			
FRACTIONAL ±		ENG APPR.			
ANGULAR: MACH ± BEND ±		MFG APPR.			
TWO PLACE DECIMAL ±		Q.A.			
THREE PLACE DECIMAL ±				TITLE: 24 IN PALMER BOWLUS FLUME	
INTERPRET GEOMETRIC TOLERANCING PER:				Project: WITH OPTIONS	
MATERIAL POLYESTER RESIN				SIZE DWG. NO. REV	
FINISH				B A	
DO NOT SCALE DRAWING		3rd ANGLE PROJECTION		SCALE: 1:14 Weight 117.09 SHEET 1 OF 5	

PROPRIETARY AND CONFIDENTIAL
 THE INFORMATION CONTAINED IN THIS DRAWING IS THE SOLE PROPERTY OF VIRTUAL POLYMER COMPOUNDS, LLC. ANY REPRODUCTION IN PART OR AS A WHOLE WITHOUT THE WRITTEN PERMISSION OF VIRTUAL POLYMER COMPOUNDS, LLC IS PROHIBITED.

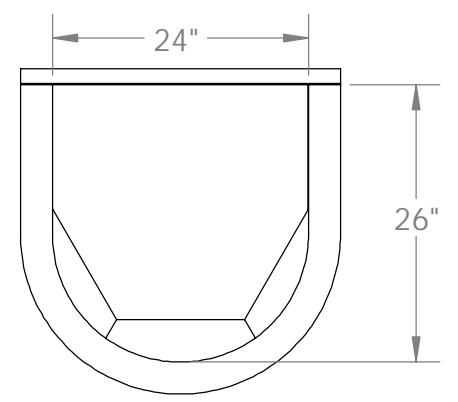
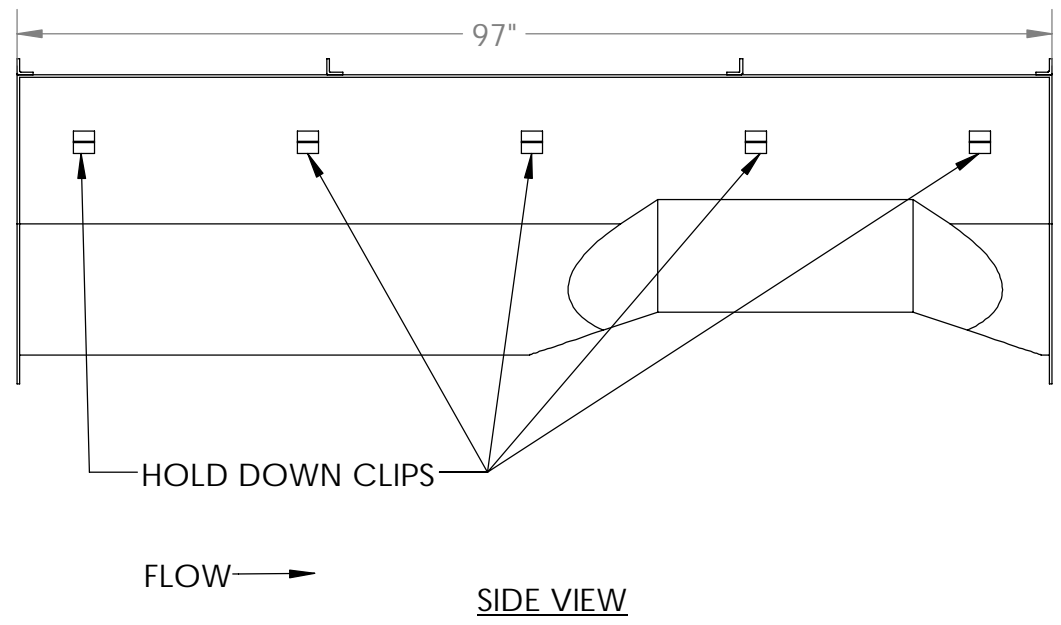
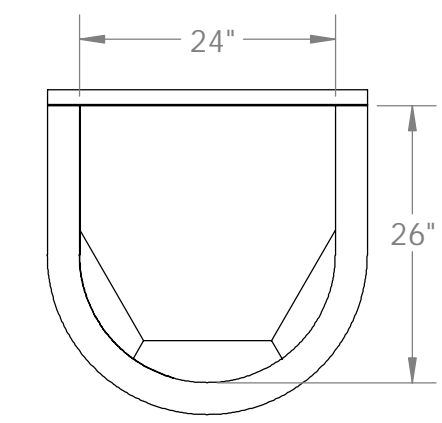
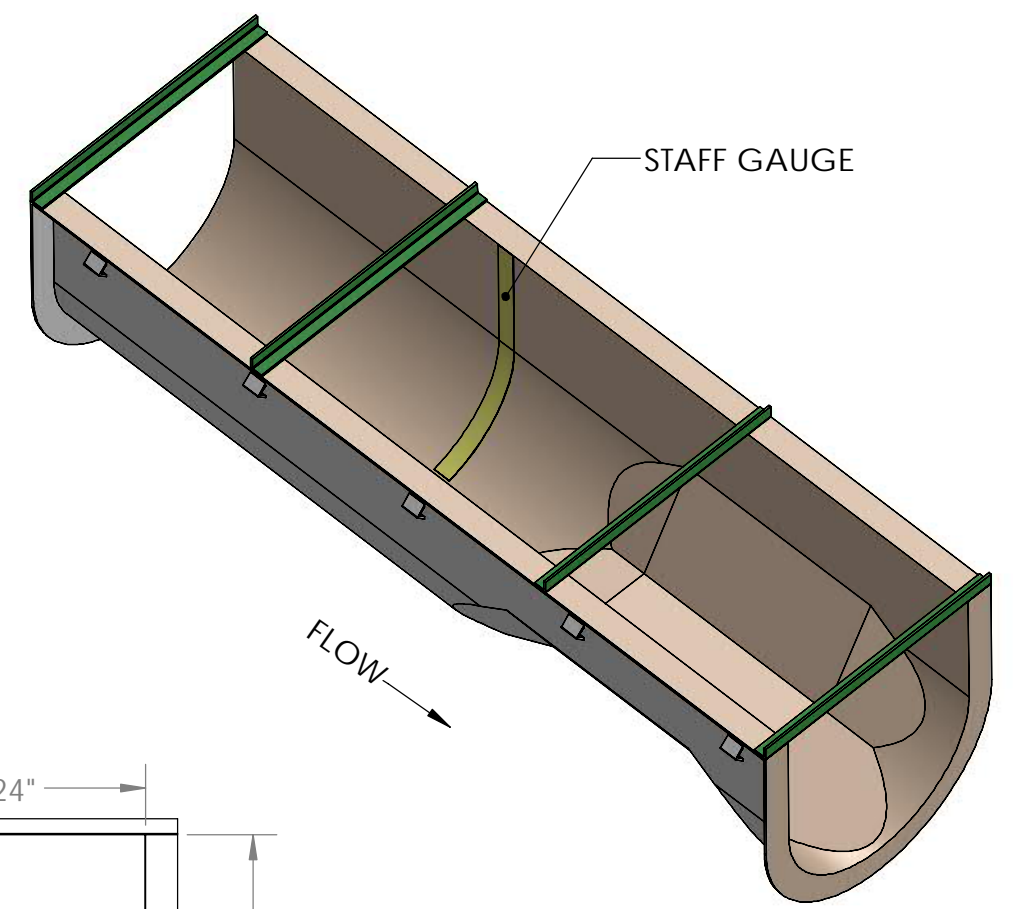
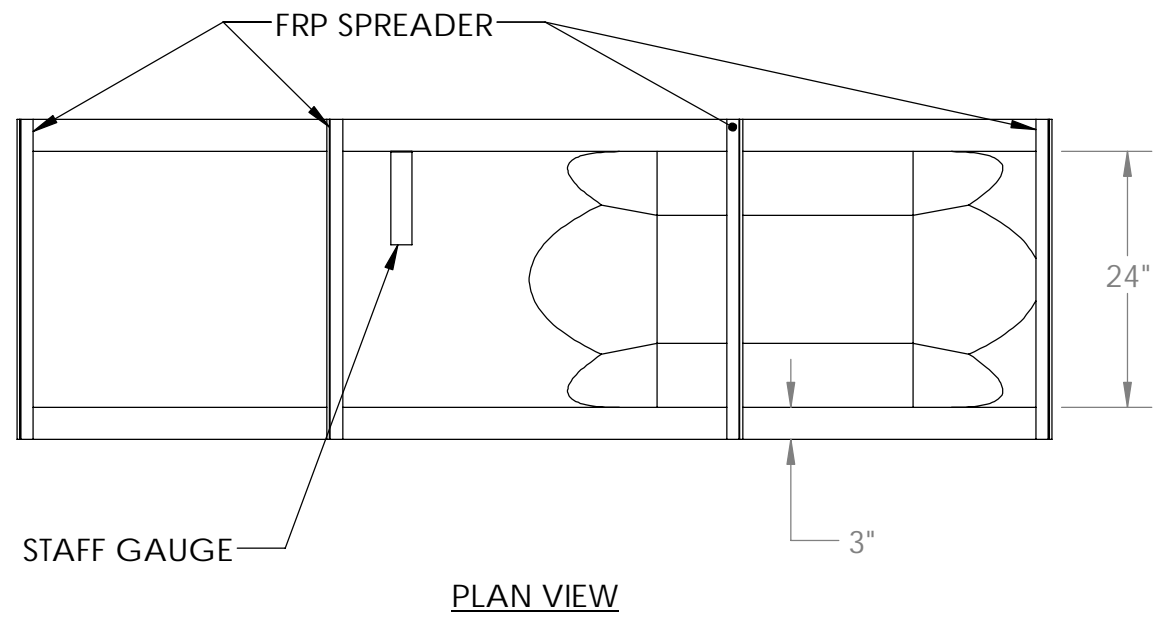

- NOTES:
- 1) INTERIOR GEL COAT COLOR TO BE BEIGE.
 - 2) EXTERIOR GEL COAT COLOR TO BE WHITE.
 - 3) NOMINAL MATERIAL THICKNESS = 1/4".

UNLESS OTHERWISE SPECIFIED:		NAME	DATE	 VPC FIBERGLASS 10478 Ridge Rd., Medina NY 14103 Toll Free: 888-290-9522 Phone: 585-735-9668	
DIMENSIONS ARE IN INCHES		DRAWN	LVR		10/5/2020
TOLERANCES:		CHECKED			
FRACTIONAL ±		ENG APPR.			
ANGULAR: MACH ± BEND ±		MFG APPR.			
TWO PLACE DECIMAL ±		Q.A.			
THREE PLACE DECIMAL ±				TITLE: 24 IN PALMER BOWLUS FLUME	
INTERPRET GEOMETRIC TOLERANCING PER:				Project: WITHOUT OPTIONS	
MATERIAL POLYESTER RESIN				SIZE DWG. NO. REV	
FINISH				B A	
DO NOT SCALE DRAWING		3rd ANGLE PROJECTION		SCALE: 1:18 Weight 68.23 SHEET 2 OF 5	

PROPRIETARY AND CONFIDENTIAL
 THE INFORMATION CONTAINED IN THIS DRAWING IS THE SOLE PROPERTY OF VIRTUAL POLYMER COMPOUNDS, LLC. ANY REPRODUCTION IN PART OR AS A WHOLE WITHOUT THE WRITTEN PERMISSION OF VIRTUAL POLYMER COMPOUNDS, LLC IS PROHIBITED.

8 7 6 5 4 3 2 1

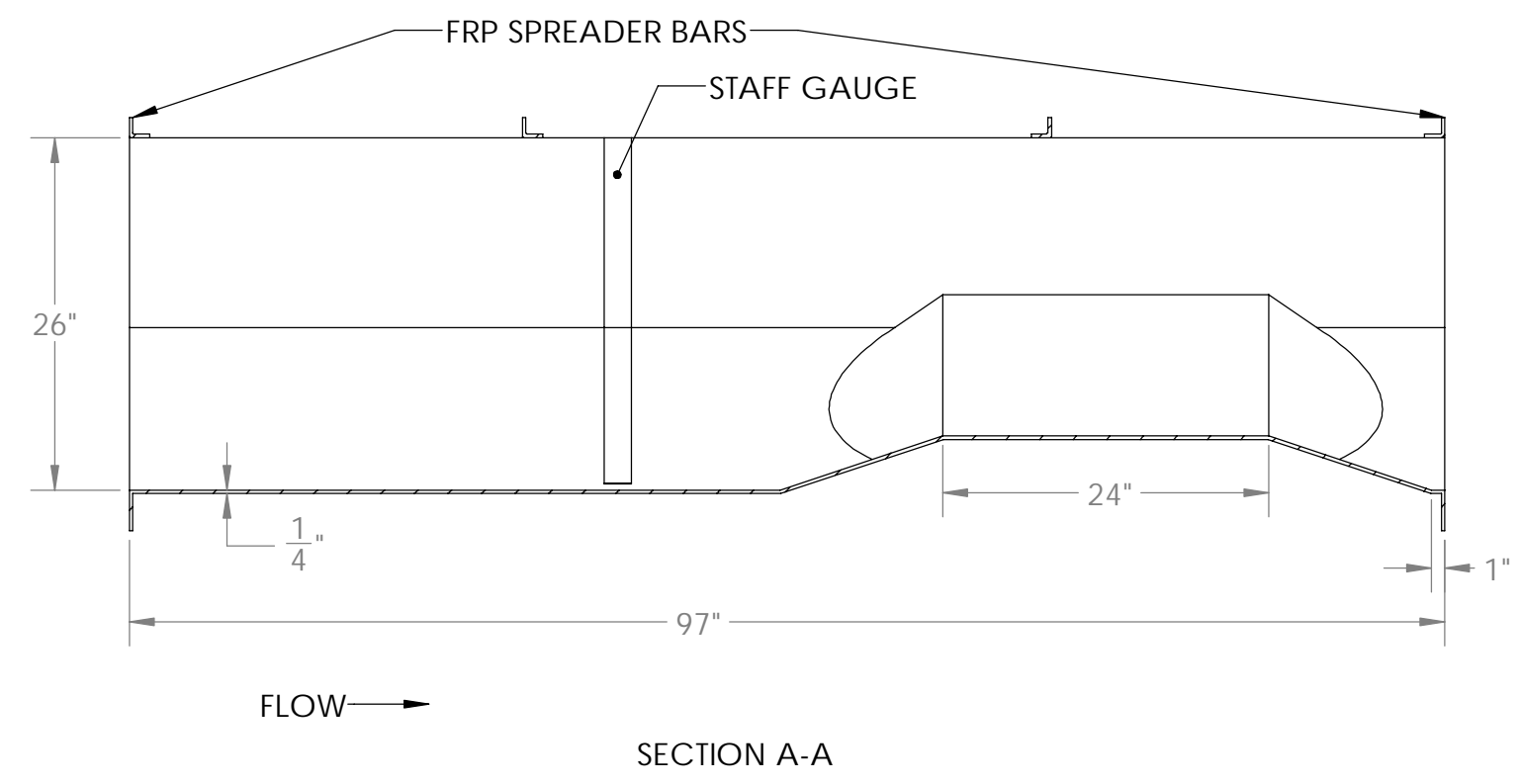
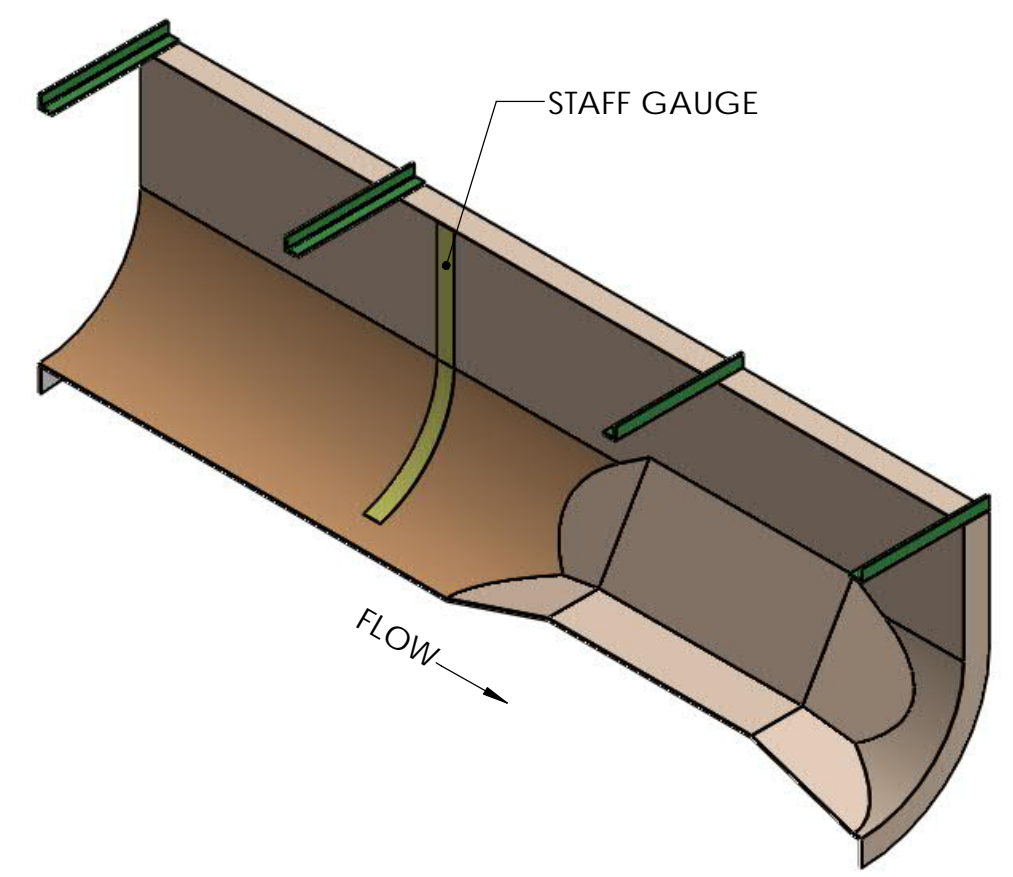
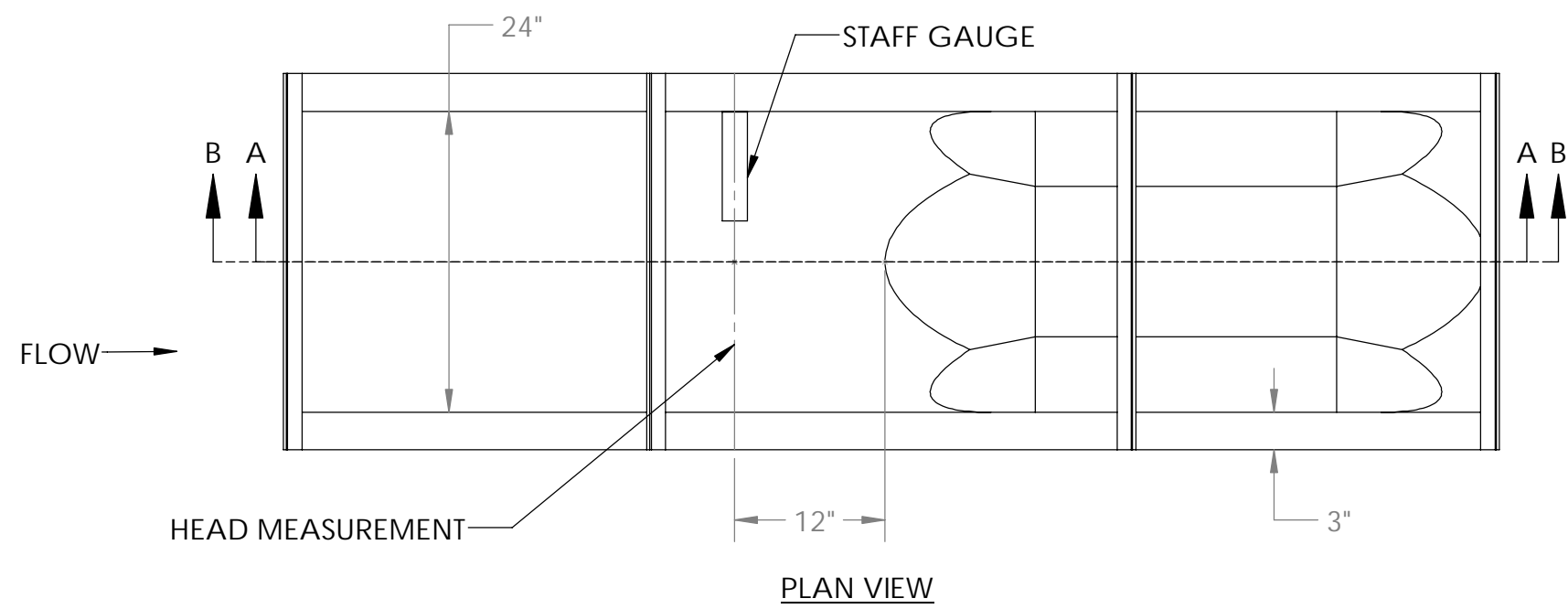

PROPRIETARY AND CONFIDENTIAL
THE INFORMATION CONTAINED IN THIS DRAWING IS THE SOLE PROPERTY OF Virtual Polymer Compounds, LLC. ANY REPRODUCTION IN PART OR AS A WHOLE WITHOUT THE WRITTEN PERMISSION OF Virtual Polymer Compounds, LLC IS PROHIBITED.

UNLESS OTHERWISE SPECIFIED:

DIMENSIONS ARE IN INCHES
TOLERANCES:
FRACTIONAL ±
ANGULAR: MACH ± BEND ±
TWO PLACE DECIMAL ±
THREE PLACE DECIMAL ±

INTERPRET GEOMETRIC TOLERANCING PER:

MATERIAL
POLYESTER RESIN
FINISH

DO NOT SCALE DRAWING

	NAME	DATE
DRAWN	LVR	10/5/2020
CHECKED		
ENG APPR.		
MFG APPR.		
Q.A.		

COMMENTS:

3rd ANGLE PROJECTION

10478 Ridge Rd.,
Medina NY 14103
Toll Free: 888-290-9522
Phone: 585-735-9668

TITLE:
24 IN PALMER BOWLUS FLUME

Project:
WITHOUT OPTIONS

SIZE B	DWG. NO.	REV A
------------------	----------	----------

SCALE: 1:14 Weight 68.23 SHEET 3 OF 5

8 7 6 5 4 3 2 1

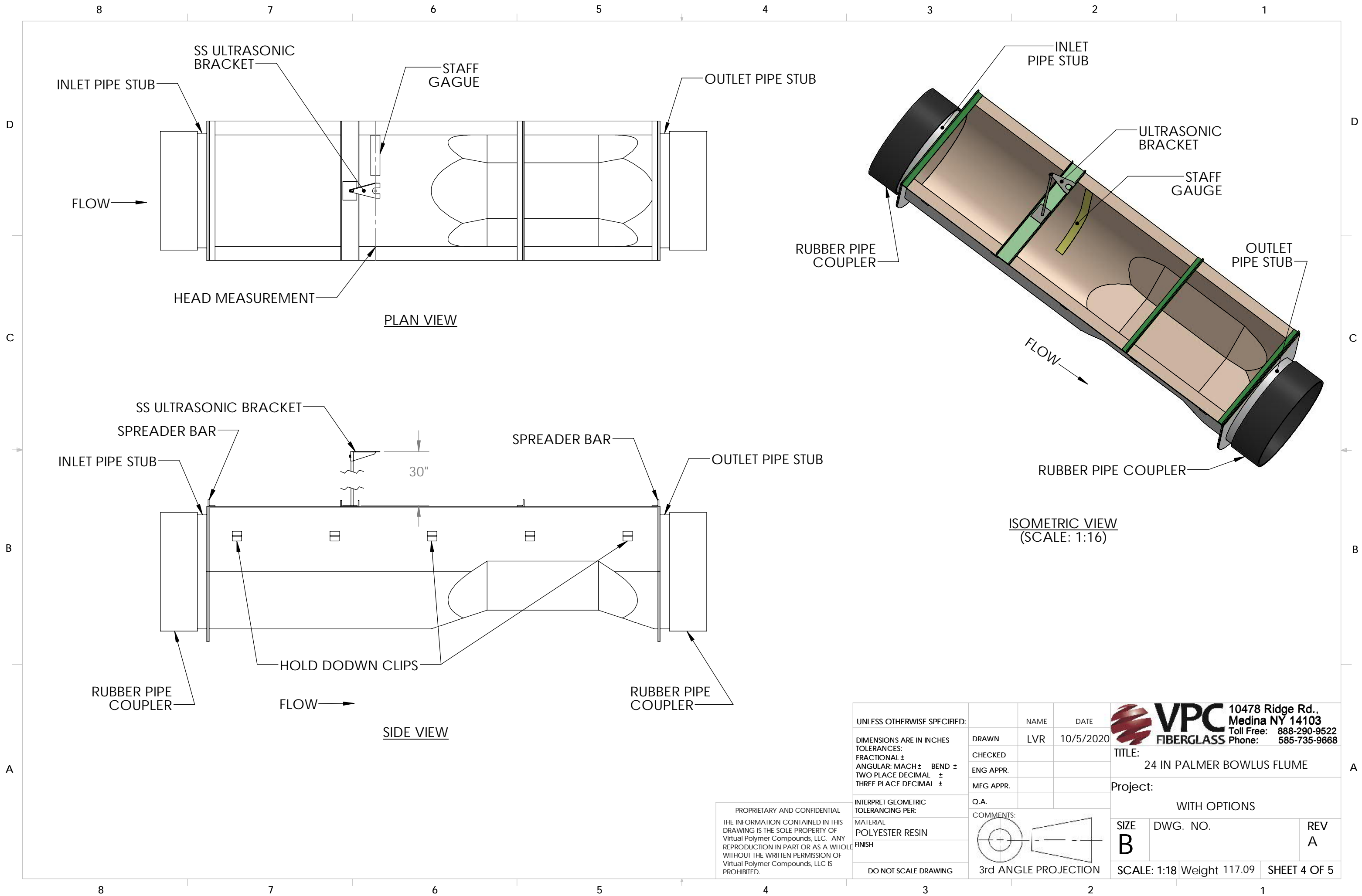

PROPRIETARY AND CONFIDENTIAL
 THE INFORMATION CONTAINED IN THIS DRAWING IS THE SOLE PROPERTY OF Virtual Polymer Compounds, LLC. ANY REPRODUCTION IN PART OR AS A WHOLE WITHOUT THE WRITTEN PERMISSION OF Virtual Polymer Compounds, LLC IS PROHIBITED.

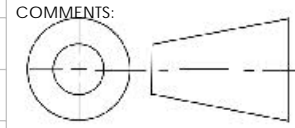
UNLESS OTHERWISE SPECIFIED:		NAME	DATE	 VPC 10478 Ridge Rd., Medina NY 14103 Toll Free: 888-290-9522 Phone: 585-735-9668	
DIMENSIONS ARE IN INCHES		DRAWN	LVR		10/5/2020
TOLERANCES:		CHECKED			
FRACTIONAL ±		ENG APPR.			
ANGULAR: MACH ± BEND ±		MFG APPR.			
TWO PLACE DECIMAL ±		Q.A.			
THREE PLACE DECIMAL ±		COMMENTS:			
INTERPRET GEOMETRIC TOLERANCING PER:				TITLE: 24 IN PALMER BOWLUS FLUME	
MATERIAL		POLYESTER RESIN FINISH		Project: WITH OPTIONS	
DO NOT SCALE DRAWING		3rd ANGLE PROJECTION		SIZE B	
				DWG. NO. SCALE: 1:18 Weight 117.09 SHEET 4 OF 5	
				REV A	

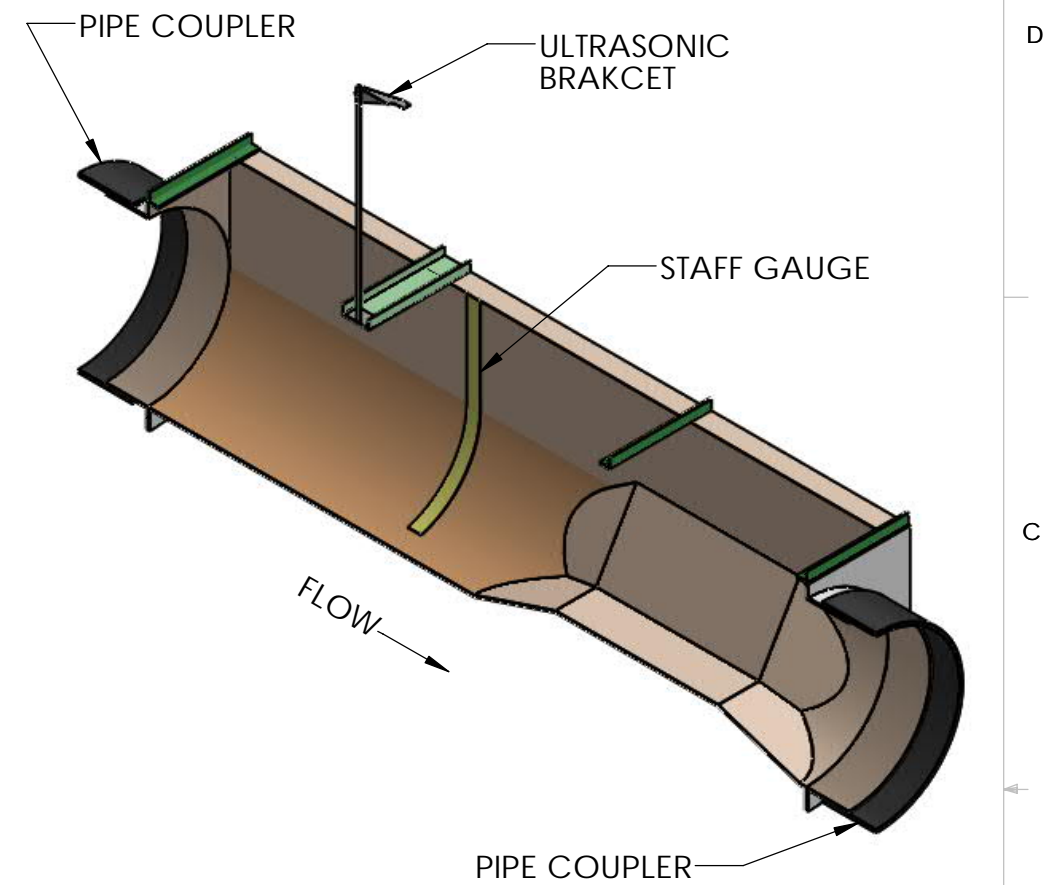
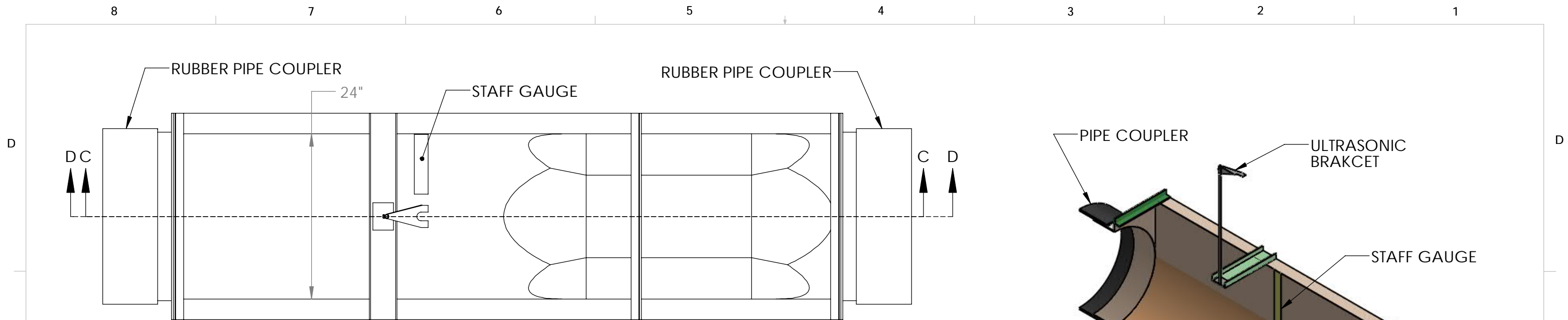

SECTION D-D
SCALE 1 : 20

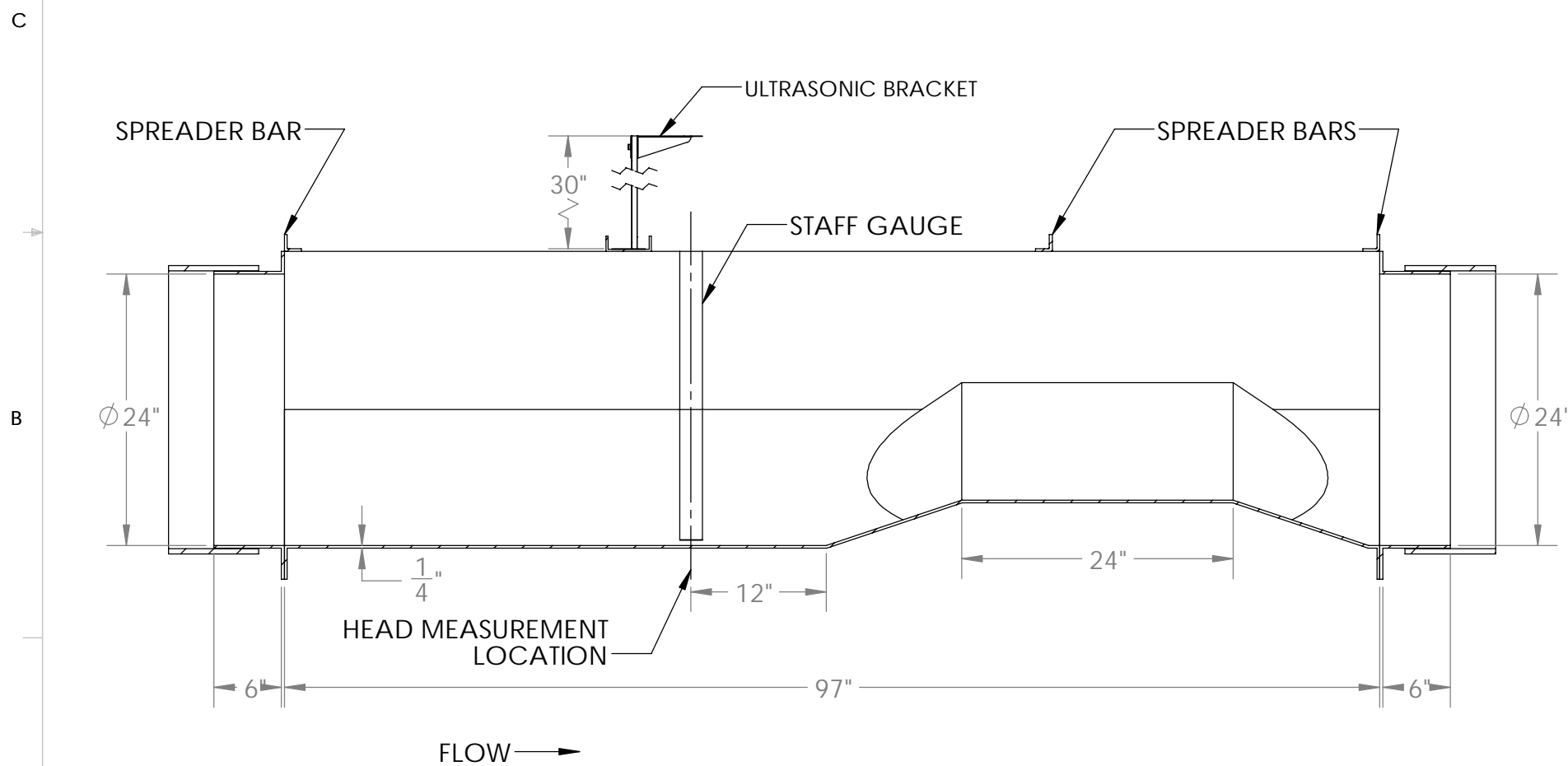

PROPRIETARY AND CONFIDENTIAL
THE INFORMATION CONTAINED IN THIS DRAWING IS THE SOLE PROPERTY OF Virtual Polymer Compounds, LLC. ANY REPRODUCTION IN PART OR AS A WHOLE WITHOUT THE WRITTEN PERMISSION OF Virtual Polymer Compounds, LLC IS PROHIBITED.

UNLESS OTHERWISE SPECIFIED:		NAME	DATE	 VPC 10478 Ridge Rd., Medina NY 14103 Toll Free: 888-290-9522 Phone: 585-735-9668
DIMENSIONS ARE IN INCHES TOLERANCES: FRACTIONAL ± ANGULAR: MACH ± BEND ± TWO PLACE DECIMAL ± THREE PLACE DECIMAL ±		DRAWN	LVR	
INTERPRET GEOMETRIC TOLERANCING PER:		CHECKED		TITLE: 24 IN PALMER BOWLUS FLUME
MATERIAL POLYESTER RESIN FINISH		ENG APPR.		Project: WITH OPTIONS
DO NOT SCALE DRAWING		MFG APPR.		SIZE B
3rd ANGLE PROJECTION		Q.A.		DWG. NO.
		COMMENTS:		REV A
				SCALE: 1:14 Weight 117.09 SHEET 5 OF 5