

8 7 6 5 4 3 2 1

D  
C  
B  
A

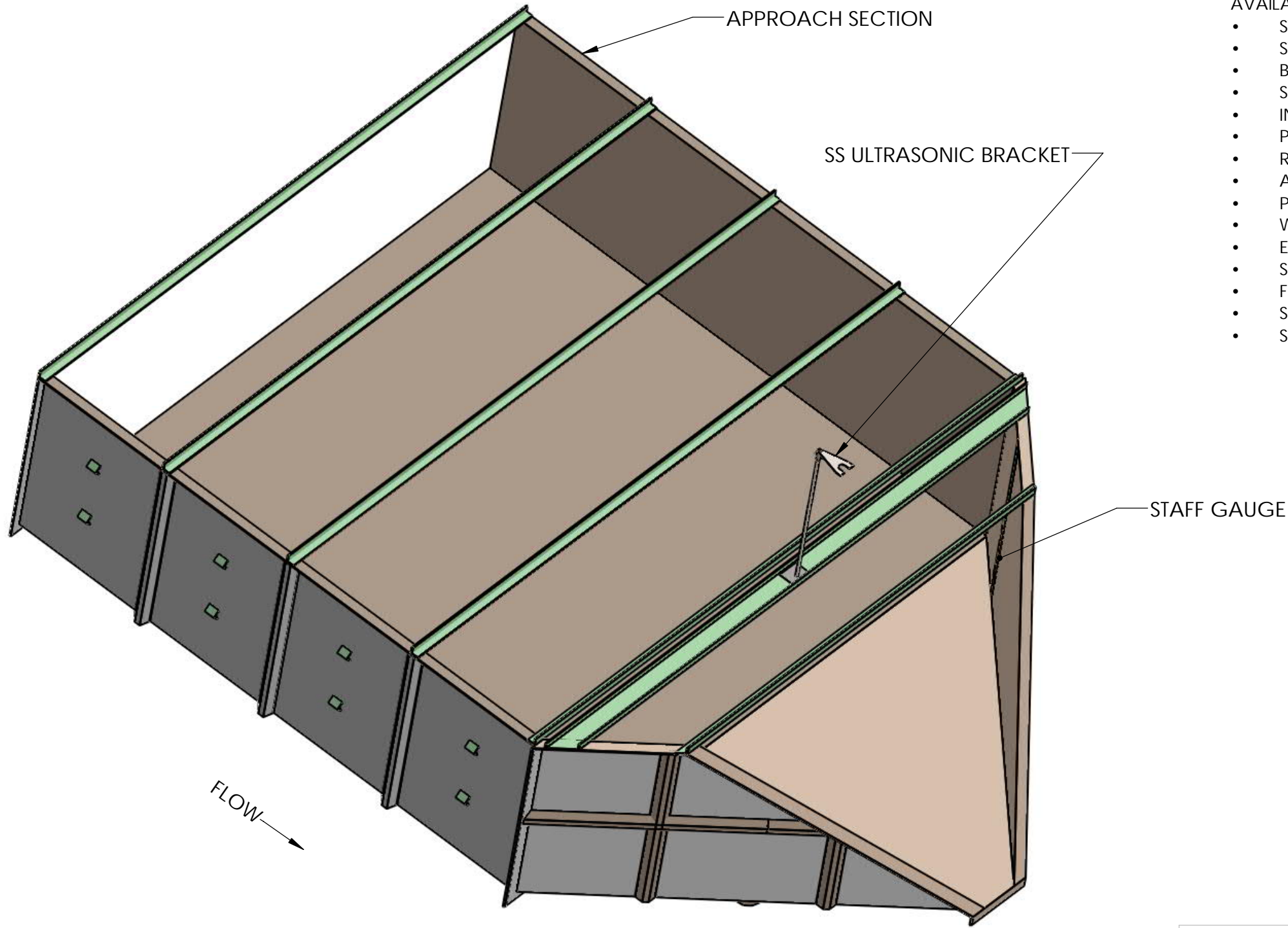

AVAILABLE OPTIONS:

- STAFF GAUGE (ENGLISH OR METRIC).
- STILLING WELL (INTEGRAL OR REMOTE).
- BUBBLER TUBE (SS 1/8" ID, INTEGRAL OR REMOVABLE).
- SAMPLER TUBE (SS 3/8" ID, INTEGRAL OR REMOVABLE).
- INLET APPROACH SECTIONS.
- PIPE STUBS.
- RUBBER PIPE COUPLERS W/ SS CLAMP BANDS.
- ADJUSTABLE SS ULTRASONIC BRACKET.
- PH PROBE CAVITY.
- WING WALLS.
- ENERGY ABSORBING RACKS. (FIXED OR REMOVABLE).
- STANDARD OR SPECIAL DEPTHS (INCLUDING SURGE BOXES).
- FLUME COVERS (GRATING, FIBER SHEETING, CLEAR POLYCARBONATE).
- SPECIAL DESIGN (TO MEET SPECIAL PROJECT NEEDS).
- STANDARD COLOR IS BEIGE (CUSTOM COLORS AVAILABLE).

FLOW →

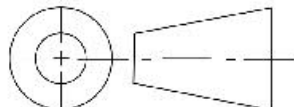
UNLESS OTHERWISE SPECIFIED:		NAME	DATE	 <b>VPC</b> FIBERGLASS 10478 Ridge Rd., Medina NY 14103 Toll Free: 888-290-9522 Phone: 585-735-9668					
DIMENSIONS ARE IN INCHES TOLERANCES: FRACTIONAL ± ANGULAR: MACH ± BEND ± TWO PLACE DECIMAL ± THREE PLACE DECIMAL ±		DRAWN	LVR		1/4/2021				
INTERPRET GEOMETRIC TOLERANCING PER:		CHECKED			TITLE:	3.0HL FLUME			
MATERIAL POLYESTER RESIN FINISH		ENG APPR.			Project:	WITH OPTIONS			
DO NOT SCALE DRAWING		MFG APPR.			Q.A.				
PROPRIETARY AND CONFIDENTIAL THE INFORMATION CONTAINED IN THIS DRAWING IS THE SOLE PROPERTY OF VIRTUAL POLYMER COMPOUNDS, LLC. ANY REPRODUCTION IN PART OR AS A WHOLE WITHOUT THE WRITTEN PERMISSION OF VIRTUAL POLYMER COMPOUNDS, LLC IS PROHIBITED.		 3rd ANGLE PROJECTION		SIZE	DWG. NO.	REV	A		
				B			SCALE: 1:20	Weight 438.66	SHEET 1 OF 5

8 7 6 5 4 3 2 1

8 7 6 5 4 3 2 1

D

C

B

A

D

C

B

A

HEAD MEASUREMENT LOCATION

FLOW →

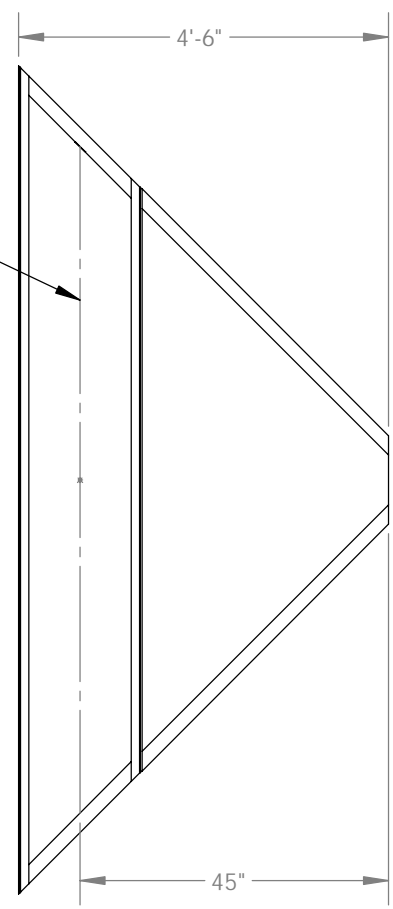

PLAN VIEW

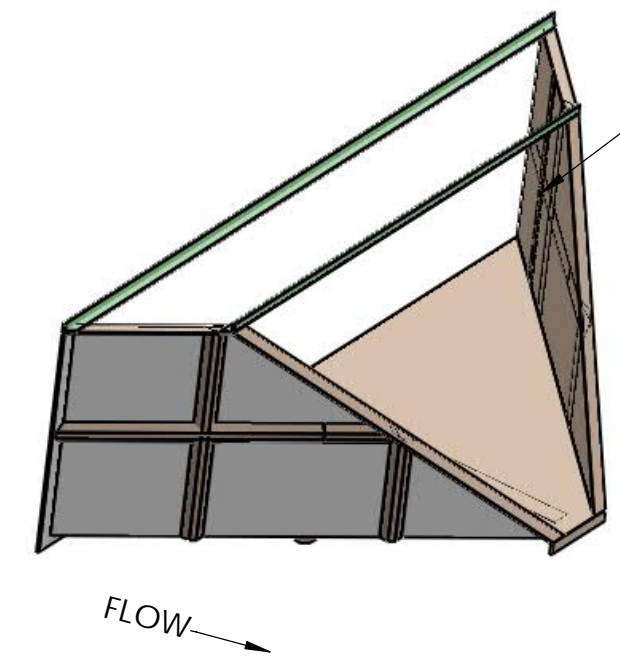

STAFF GAUGE

FLOW →

ISOMETRIC VIEW

STAFF GAUGE

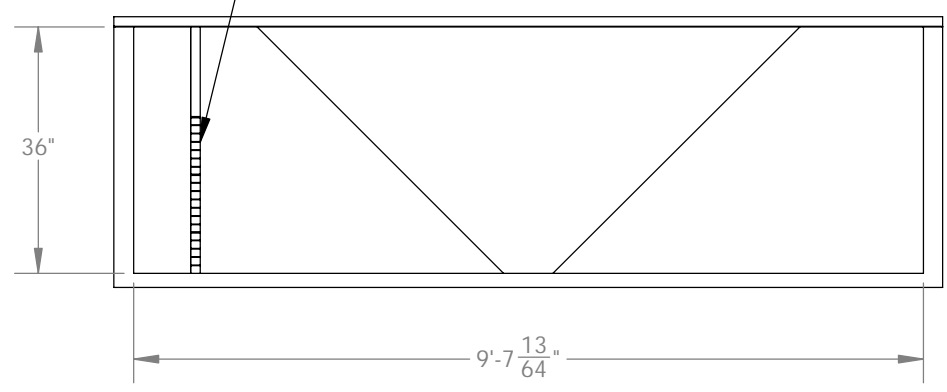

END VIEW  
(LOOKING DOWN STREAM)

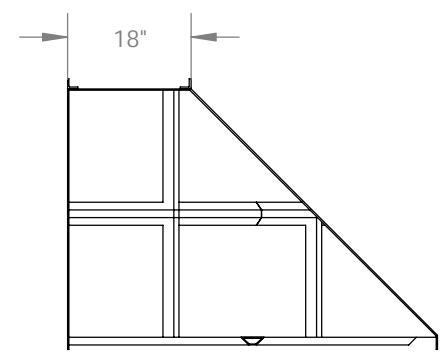

FLOW →

SIDE VIEW

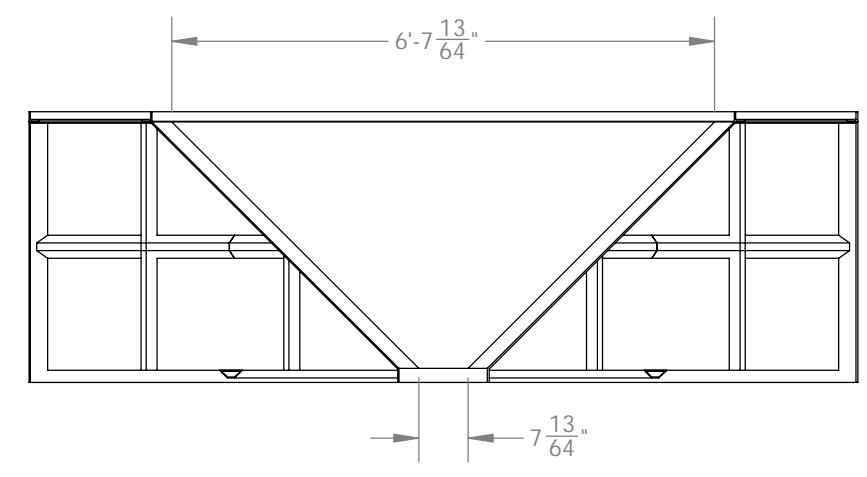

END VIEW  
(LOOKING UP STREAM)

UNLESS OTHERWISE SPECIFIED:

DIMENSIONS ARE IN INCHES  
TOLERANCES:  
FRACTIONAL ±  
ANGULAR: MACH ± BEND ±  
TWO PLACE DECIMAL ±  
THREE PLACE DECIMAL ±

INTERPRET GEOMETRIC TOLERANCING PER:

MATERIAL  
POLYESTER RESIN  
FINISH

DO NOT SCALE DRAWING

NAME DATE

DRAWN LVR 1/4/2021

CHECKED

ENG APPR.

MFG APPR.

Q.A.

COMMENTS:

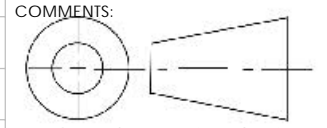

3rd ANGLE PROJECTION



10478 Ridge Rd.,  
Medina NY 14103  
Toll Free: 888-290-9522  
Phone: 585-735-9668

TITLE: 3.0HL FLUME

Project: NO OPTIONS

SIZE <b>B</b>	DWG. NO.	REV A
------------------	----------	----------

SCALE: 1:28 Weight 115.77 SHEET 2 OF 5

PROPRIETARY AND CONFIDENTIAL  
THE INFORMATION CONTAINED IN THIS DRAWING IS THE SOLE PROPERTY OF Virtual Polymer Compounds, LLC. ANY REPRODUCTION IN PART OR AS A WHOLE WITHOUT THE WRITTEN PERMISSION OF Virtual Polymer Compounds, LLC IS PROHIBITED.

FLOW →

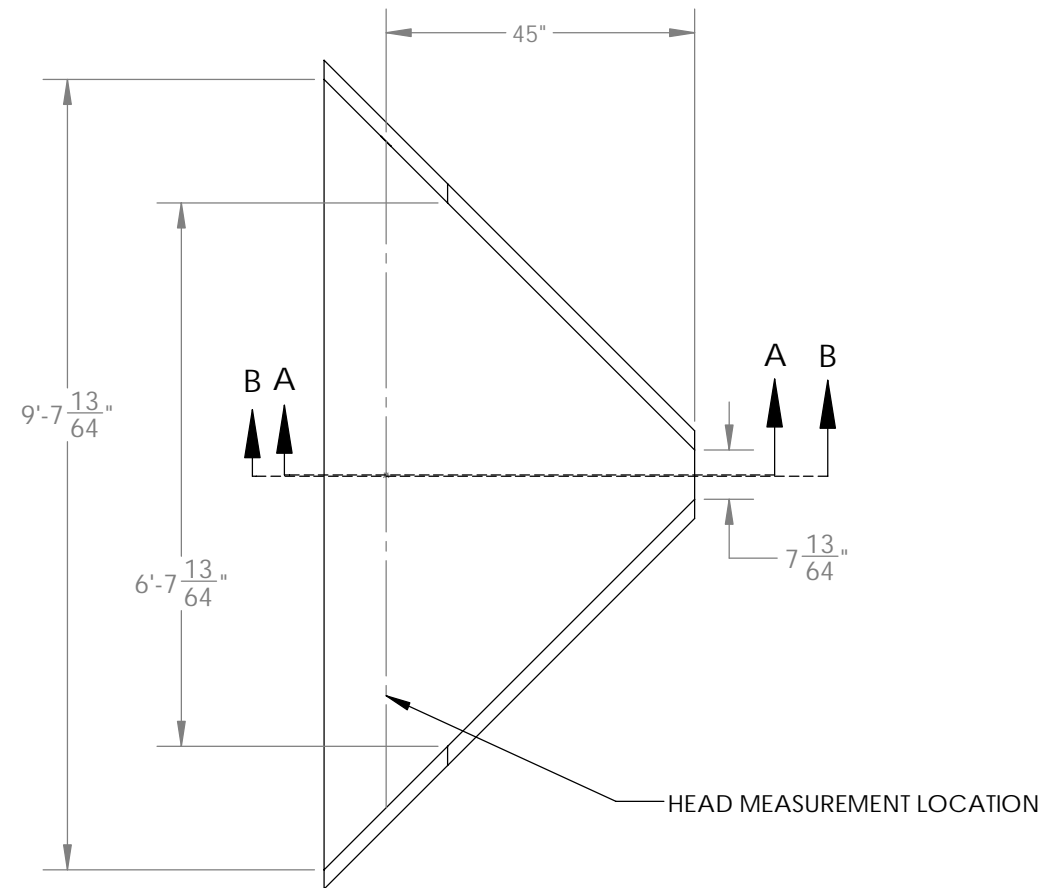

PLAN VIEW  
(SPREADER BARS REMOVED FOR CLARITY)

STAFF GAUGE

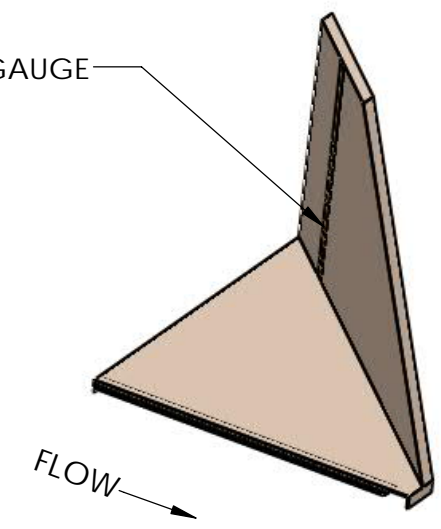

SECTION B-B

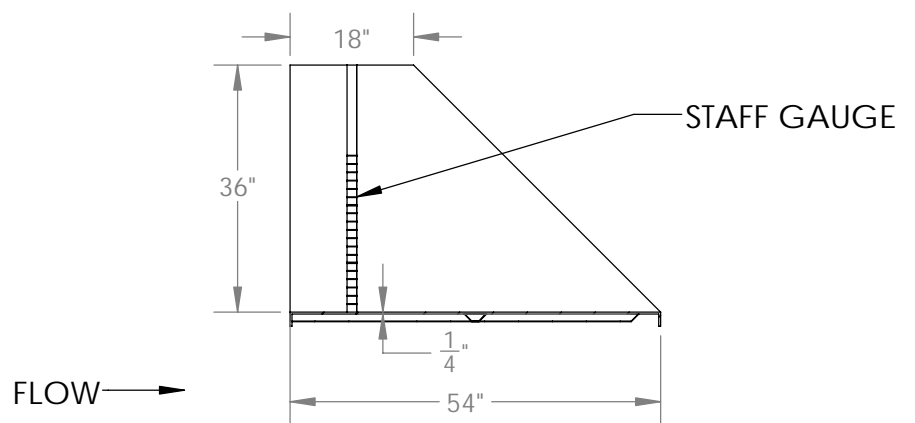

SECTION A-A

PROPRIETARY AND CONFIDENTIAL  
THE INFORMATION CONTAINED IN THIS DRAWING IS THE SOLE PROPERTY OF Virtual Polymer Compounds, LLC. ANY REPRODUCTION IN PART OR AS A WHOLE WITHOUT THE WRITTEN PERMISSION OF Virtual Polymer Compounds, LLC IS PROHIBITED.

UNLESS OTHERWISE SPECIFIED:  
DIMENSIONS ARE IN INCHES  
TOLERANCES:  
FRACTIONAL ±  
ANGULAR: MACH ± BEND ±  
TWO PLACE DECIMAL ±  
THREE PLACE DECIMAL ±

INTERPRET GEOMETRIC TOLERANCING PER:  
MATERIAL  
POLYESTER RESIN  
FINISH

DO NOT SCALE DRAWING

	NAME	DATE
DRAWN	LVR	1/4/2021
CHECKED		
ENG APPR.		
MFG APPR.		
Q.A.		

COMMENTS:  
3rd ANGLE PROJECTION

**VPC** 10478 Ridge Rd.,  
Medina NY 14103  
Toll Free: 888-290-9522  
FIBERGLASS Phone: 585-735-9668

TITLE: 3.0HL FLUME

Project: NO OPTIONS

SIZE <b>B</b>	DWG. NO.	REV A
------------------	----------	----------

SCALE: 1:28 Weight 115.77 SHEET 3 OF 5

8 7 6 5 4 3 2 1

D

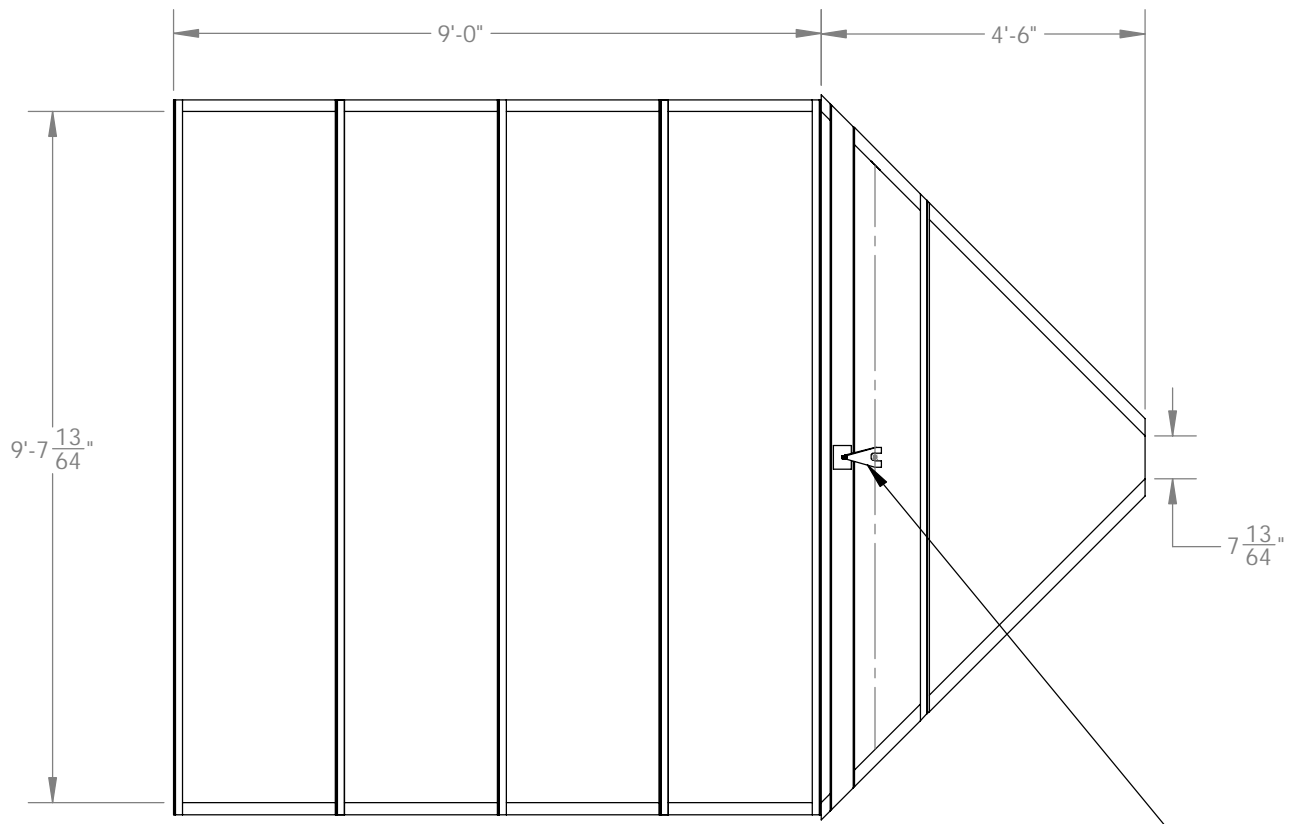

FLOW →

PLAN VIEW

SS ULTRASONIC BRACKET

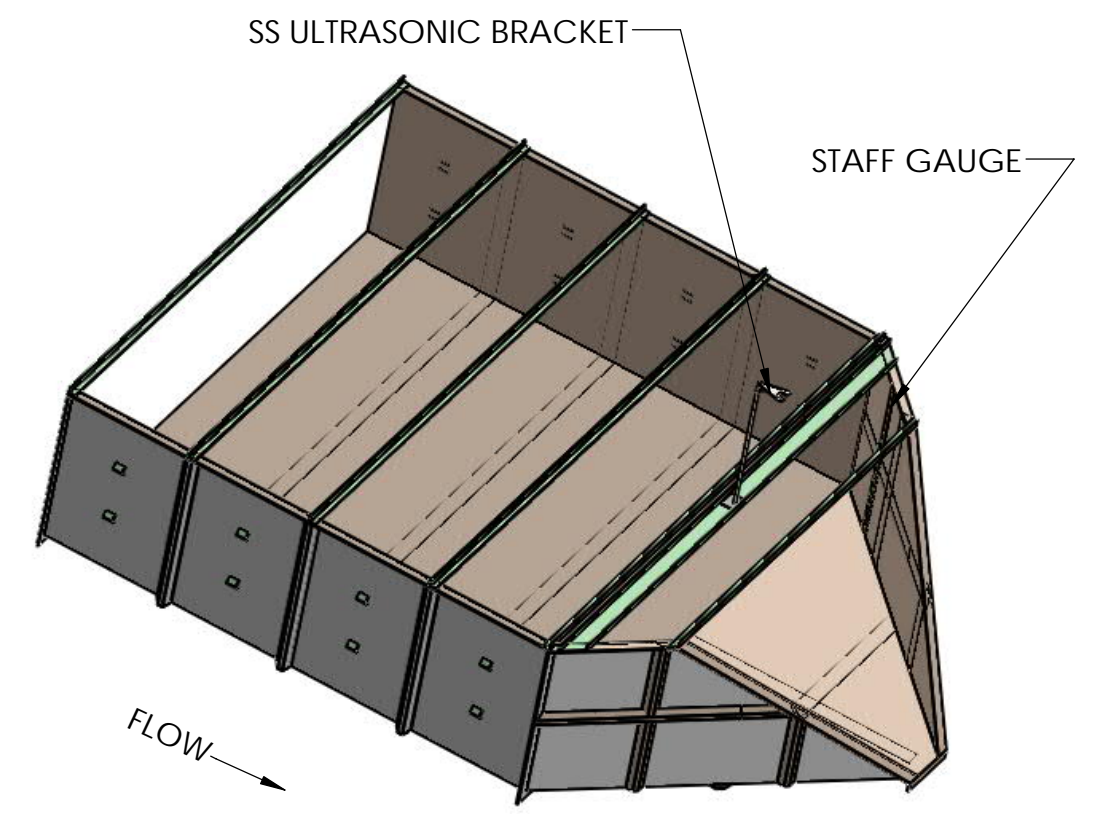

ISOMETRIC VIEW  
SCALE: 1:36

C

C

B

B

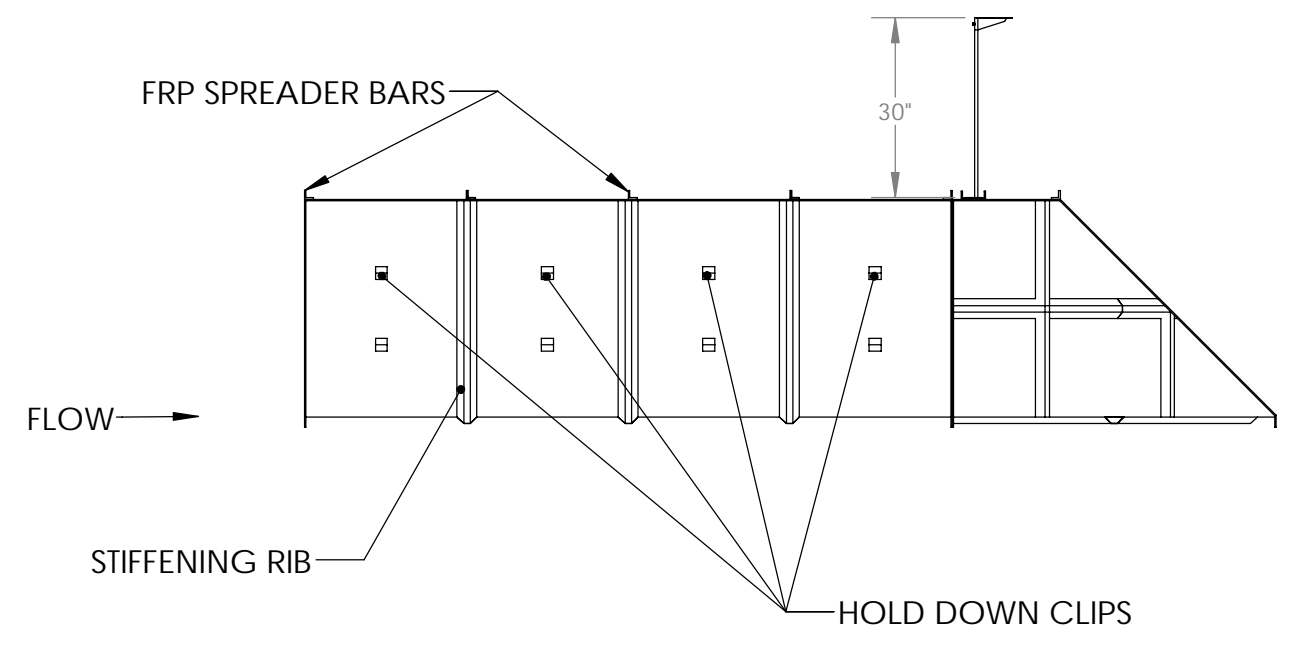

FLOW →

SIDE VIEW

A

A

PROPRIETARY AND CONFIDENTIAL  
THE INFORMATION CONTAINED IN THIS DRAWING IS THE SOLE PROPERTY OF Virtual Polymer Compounds, LLC. ANY REPRODUCTION IN PART OR AS A WHOLE WITHOUT THE WRITTEN PERMISSION OF Virtual Polymer Compounds, LLC IS PROHIBITED.

UNLESS OTHERWISE SPECIFIED:	NAME	DATE
DIMENSIONS ARE IN INCHES	DRAWN	LVR 1/4/2021
TOLERANCES:	CHECKED	
FRACTIONAL ±	ENG APPR.	
ANGULAR: MACH ± BEND ±	MFG APPR.	
TWO PLACE DECIMAL ±	Q.A.	
THREE PLACE DECIMAL ±	COMMENTS:	
INTERPRET GEOMETRIC TOLERANCING PER:		
MATERIAL	POLYESTER RESIN	
FINISH	DO NOT SCALE DRAWING	

TITLE:	3.0HL FLUME	
Project:	WITH OPTIONS	
SIZE	DWG. NO.	REV
B		A
SCALE: 1:32	Weight 438.66	SHEET 4 OF 5

**VPC** 10478 Ridge Rd., Medina NY 14103  
FIBERGLASS Toll Free: 888-290-9522 Phone: 585-735-9668

8 7 6 5 4 3 2 1

8 7 6 5 4 3 2 1

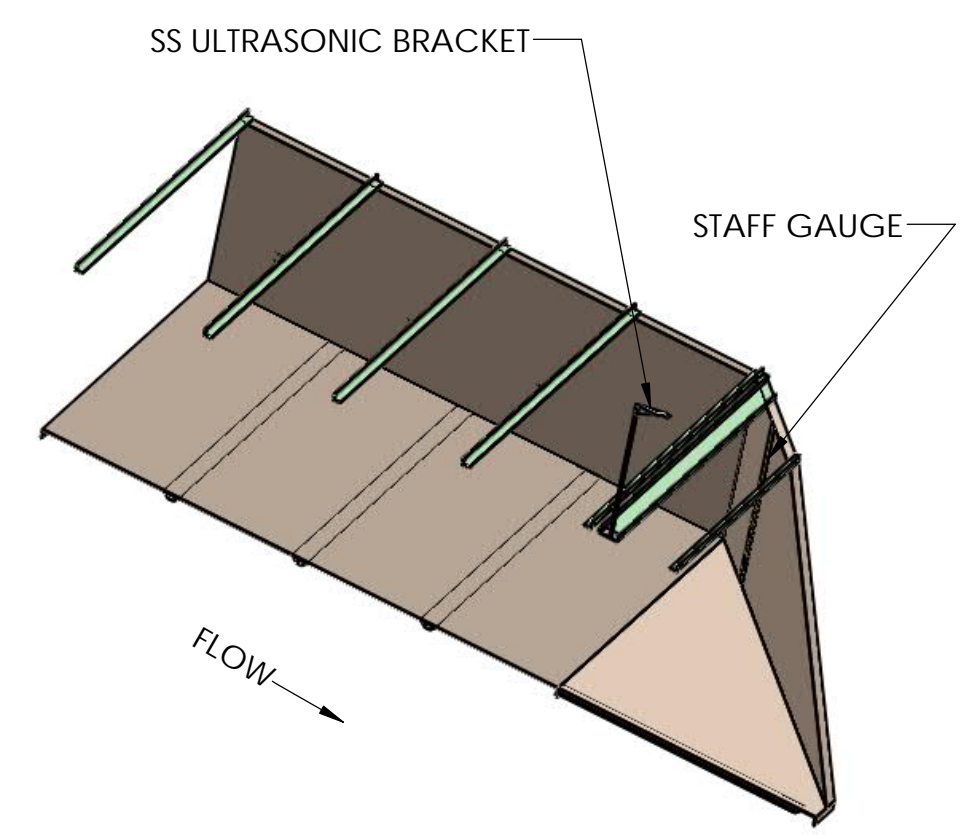
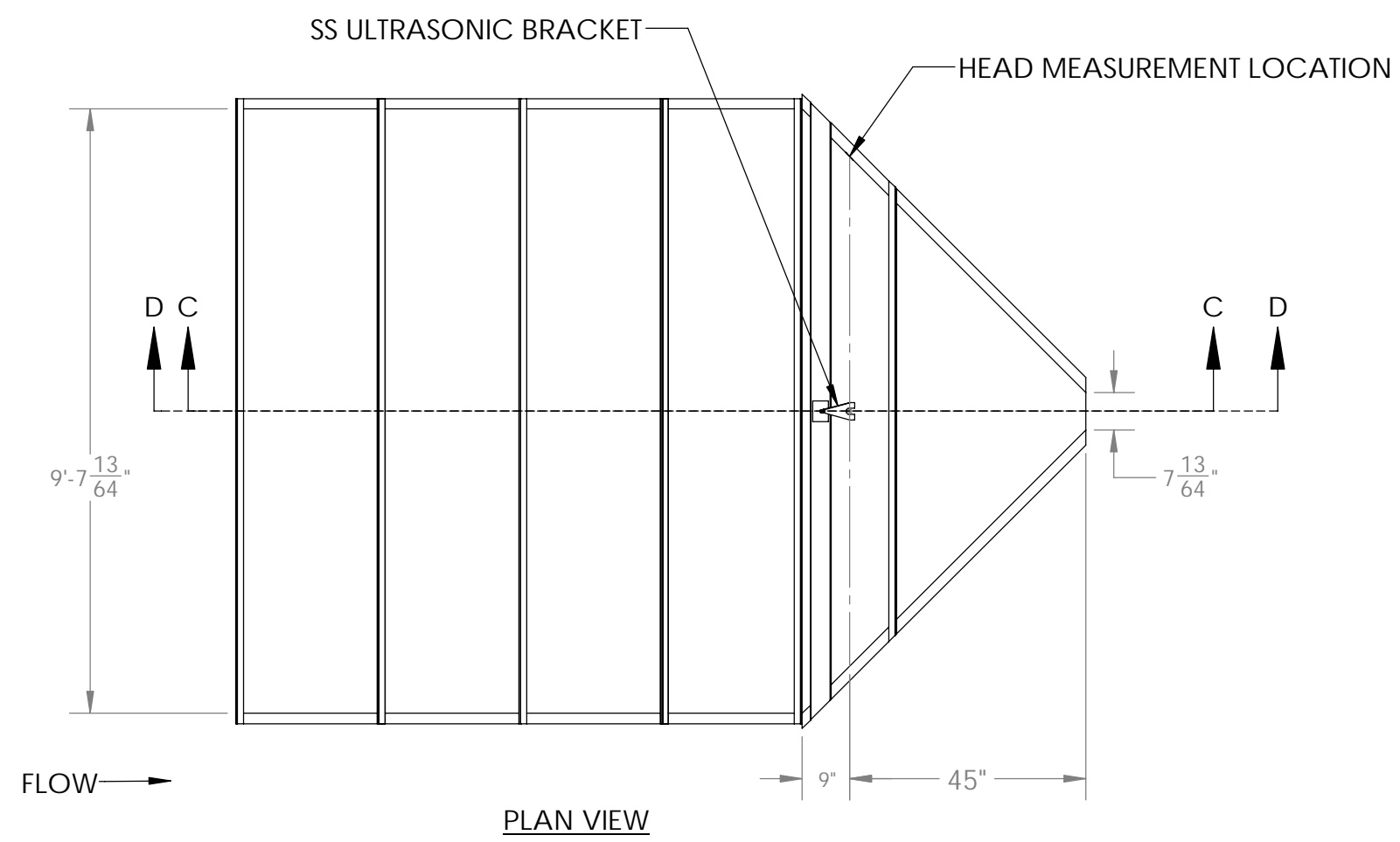

SECTION D-D  
SCALE 1 : 34

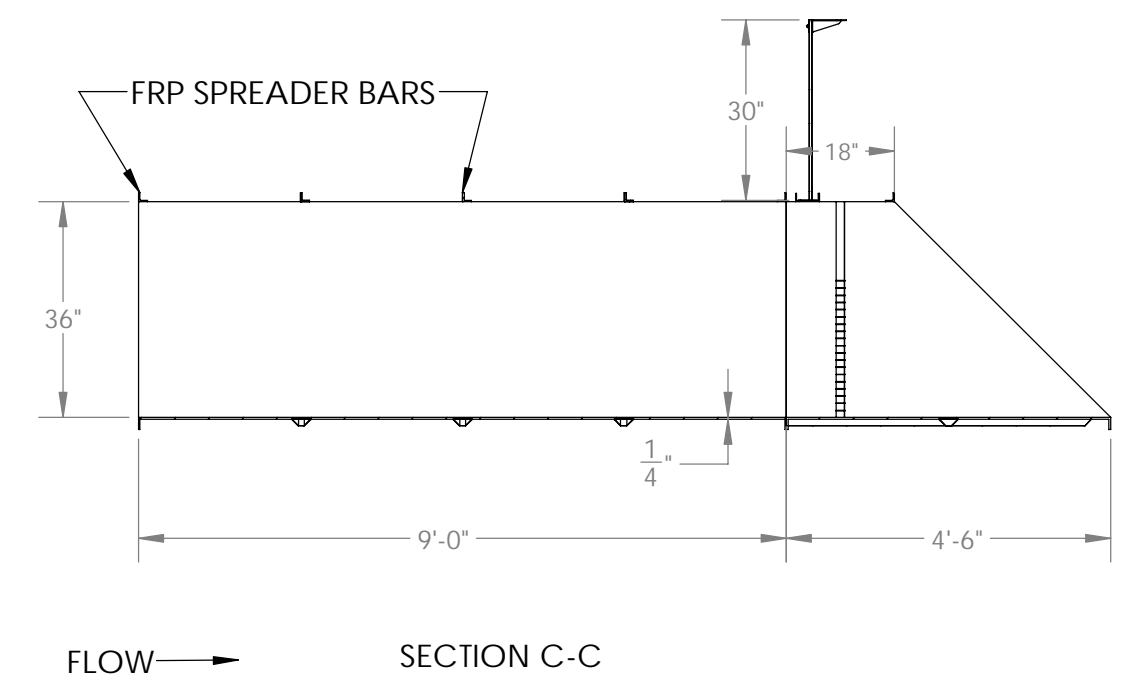

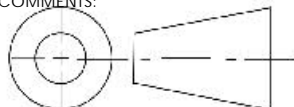
UNLESS OTHERWISE SPECIFIED:		NAME	DATE	 <b>VPC</b> 10478 Ridge Rd., Medina NY 14103 Toll Free: 888-290-9522 Phone: 585-735-9668
DIMENSIONS ARE IN INCHES TOLERANCES: FRACTIONAL ± ANGULAR: MACH ± BEND ± TWO PLACE DECIMAL ± THREE PLACE DECIMAL ±		DRAWN	LVR 1/4/2021	
INTERPRET GEOMETRIC TOLERANCING PER:		CHECKED		TITLE:
MATERIAL POLYESTER RESIN FINISH		ENG APPR.		3.0HL FLUME
DO NOT SCALE DRAWING		MFG APPR.		Project:
3rd ANGLE PROJECTION		Q.A.		WITH OPTIONS
PROPRIETARY AND CONFIDENTIAL THE INFORMATION CONTAINED IN THIS DRAWING IS THE SOLE PROPERTY OF Virtual Polymer Compounds, LLC. ANY REPRODUCTION IN PART OR AS A WHOLE WITHOUT THE WRITTEN PERMISSION OF Virtual Polymer Compounds, LLC IS PROHIBITED.		COMMENTS:		SIZE <b>B</b>
				DWG. NO.
				REV A
				SCALE: 1:32 Weight 438.66 SHEET 5 OF 5

8 7 6 5 4 3 2 1