

AVAILABLE OPTIONS:

- STAFF GAUGE (ENGLISH OR METRIC).
- STILLING WELL (INTEGRAL OR REMOTE).
- BUBBLER TUBE (SS 1/4" ID, INTEGRAL OR REMOVABLE).
- SAMPLER TUBE (SS 3/8" ID, INTEGRAL OR REMOVABLE).
- INLET AND OUTLET END ADAPTERS.
- PIPE STUBS.
- RUBBER PIPE COUPLERS W/ SS CLAMP BANDS.
- ADJUSTABLE SS ULTRASONIC BRACKET.
- PH PROBE CAVITY.
- WING WALLS AND BULK HEADS.
- ENERGY ABSORBING RACKS. (FIXED OR REMOVABLE).
- STANDARD OR SPECIAL DEPTHS (INCLUDING SURGE BOXES).
- FLUME COVERS (GRATING, FIBER SHEETING, CLEAR POLYCARBONATE).
- MONTANA CUT DESIGN.
- SPECIAL DESIGN (TO MEET SPECIAL PROJECT NEEDS).
- STANDARD COLOR IS BEIGE (CUSTOM COLORS AVAILABLE).

PROPRIETARY AND CONFIDENTIAL
 THE INFORMATION CONTAINED IN THIS DRAWING IS THE SOLE PROPERTY OF VIRTUAL POLYMER COMPOUNDS, LLC. ANY REPRODUCTION IN PART OR AS A WHOLE WITHOUT THE WRITTEN PERMISSION OF VIRTUAL POLYMER COMPOUNDS, LLC IS PROHIBITED.

UNLESS OTHERWISE SPECIFIED:	NAME	DATE	 VPC FIBERGLASS 10478 Ridge Rd., Medina NY 14103 Toll Free: 888-290-9522 Phone: 585-735-9668	
DIMENSIONS ARE IN INCHES	DRAWN	LVR		8/6/2020
TOLERANCES:	CHECKED			
FRACTIONAL ±	ENG APPR.			
ANGULAR: MACH ± BEND ±	MFG APPR.			
TWO PLACE DECIMAL ±	Q.A.			
THREE PLACE DECIMAL ±	TITLE: 3 INCH PARSHALL FLUME		Project:	
INTERPRET GEOMETRIC TOLERANCING PER:	WITH OPTIONS			
MATERIAL	SIZE DWG. NO. REV			
POLYESTER RESIN	B		A	
FINISH	SCALE: 1:10 Weight 69.76 SHEET 1 OF 5			
DO NOT SCALE DRAWING	3rd ANGLE PROJECTION			

D

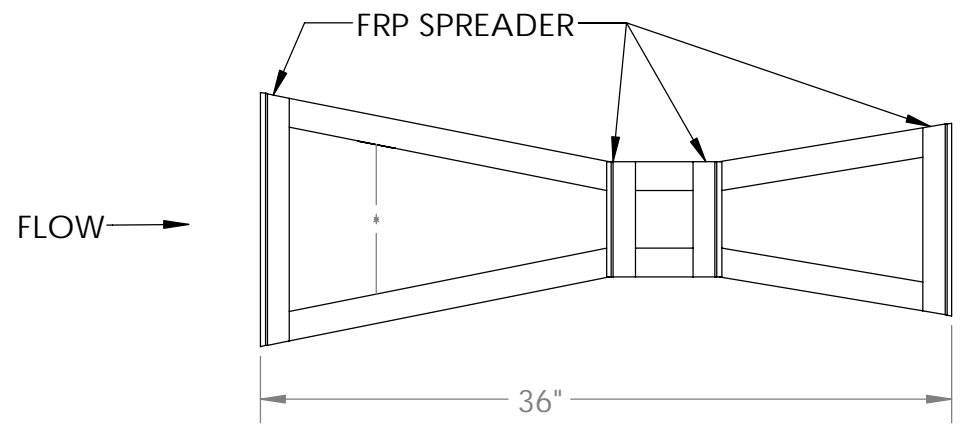

PLAN VIEW

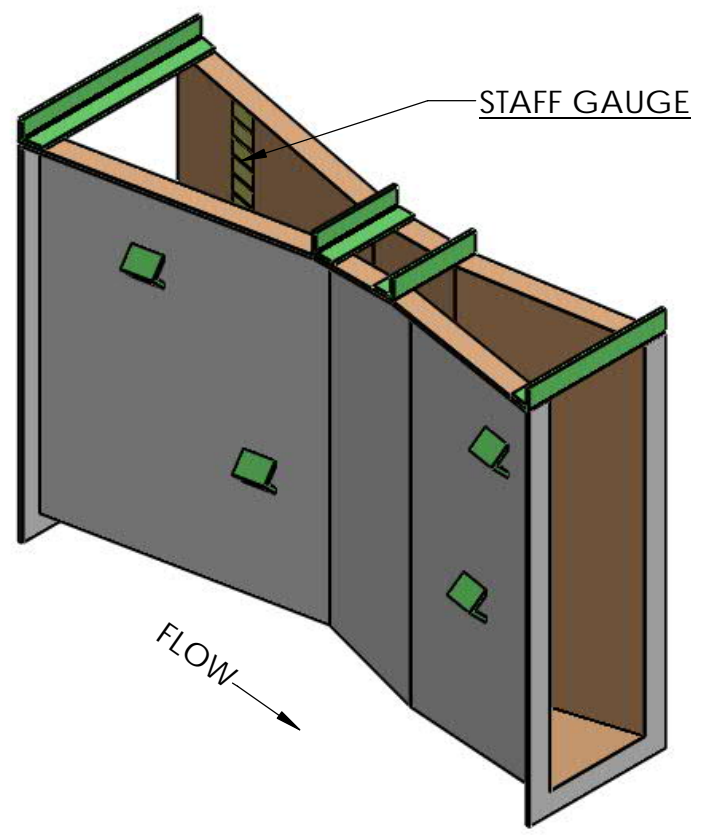

ISOMETRIC VIEW

C

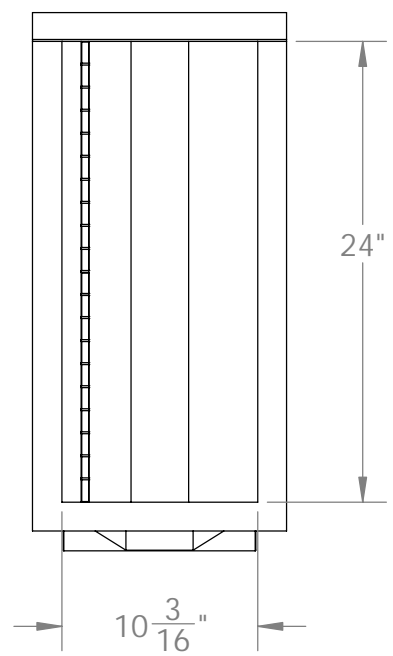

END VIEW (LOOKING DOWNSTREAM)

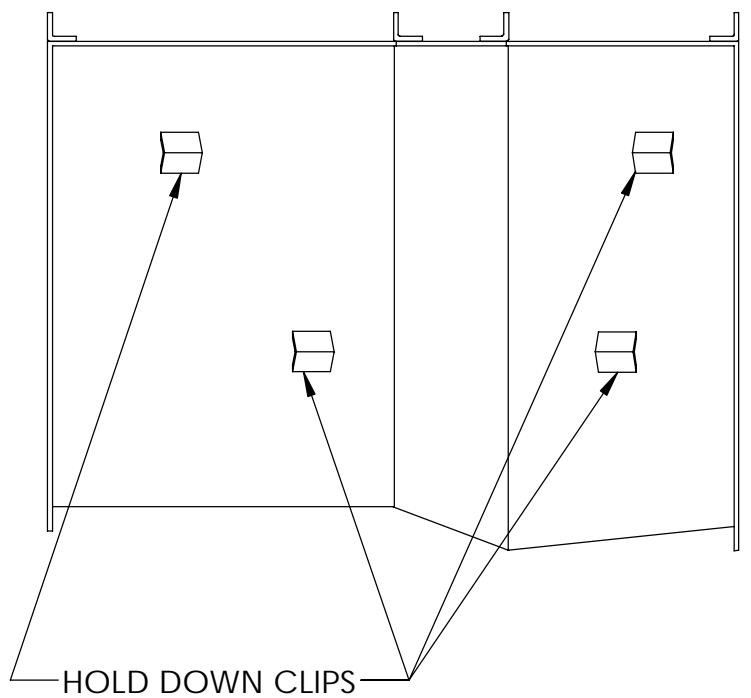

SIDE VIEW

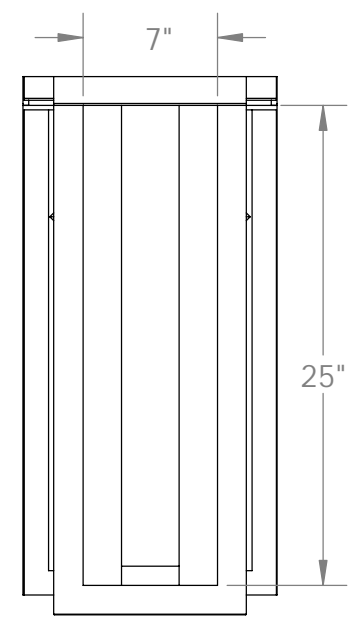

END VIEW (LOOKING UPSTREAM)

- NOTES:
 1) INTERIOR GEL COAT COLOR TO BE BEIGE.
 2) EXTERIOR GEL COAT COLOR TO BE WHITE.
 3) NOMINAL MATERIAL THICKNESS = 1/4".

A

UNLESS OTHERWISE SPECIFIED: DIMENSIONS ARE IN INCHES TOLERANCES: FRACTIONAL ± ANGULAR: MACH ± BEND ± TWO PLACE DECIMAL ± THREE PLACE DECIMAL ±	NAME	DATE	 10478 Ridge Rd., Medina NY 14103 Toll Free: 888-290-9522 Phone: 585-735-9668	
	DRAWN	LVR		8/6/2020
	CHECKED			
	ENG APPR.			
INTERPRET GEOMETRIC TOLERANCING PER:	Q.A.		TITLE:	
MATERIAL POLYESTER RESIN FINISH			3 INCH PARSHALL FLUME	
DO NOT SCALE DRAWING			Project:	
			WITHOUT OPTIONS	
			SIZE DWG. NO. REV	
			B 1 A	
			SCALE: 1:10 Weight 25.16 SHEET 2 OF 5	

PROPRIETARY AND CONFIDENTIAL
 THE INFORMATION CONTAINED IN THIS DRAWING IS THE SOLE PROPERTY OF VIRTUAL POLYMER COMPOUNDS, LLC. ANY REPRODUCTION IN PART OR AS A WHOLE WITHOUT THE WRITTEN PERMISSION OF VIRTUAL POLYMER COMPOUNDS, LLC IS PROHIBITED.

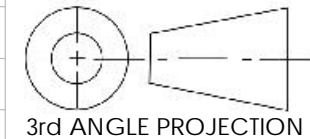

8 7 6 5 4 3 2 1

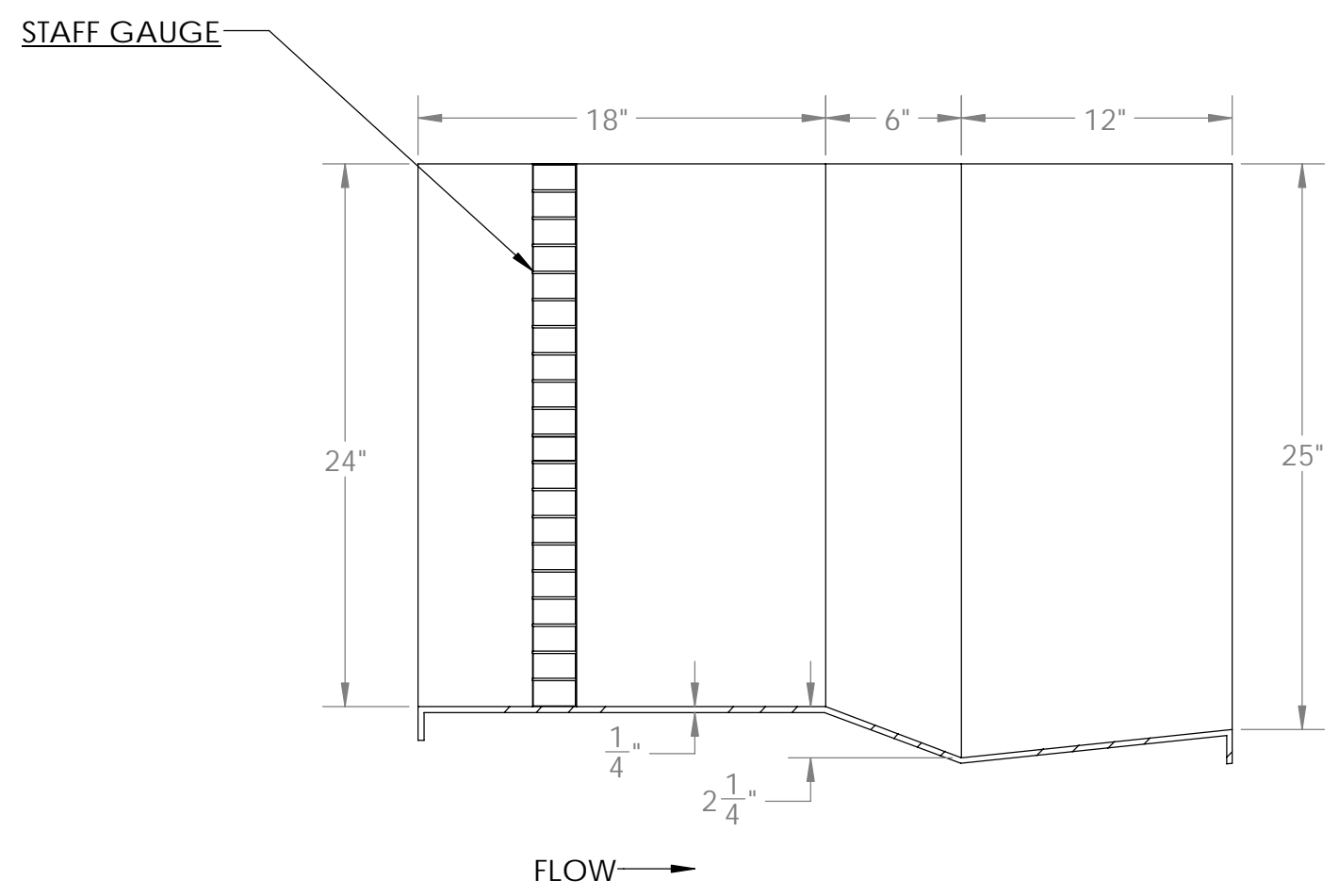
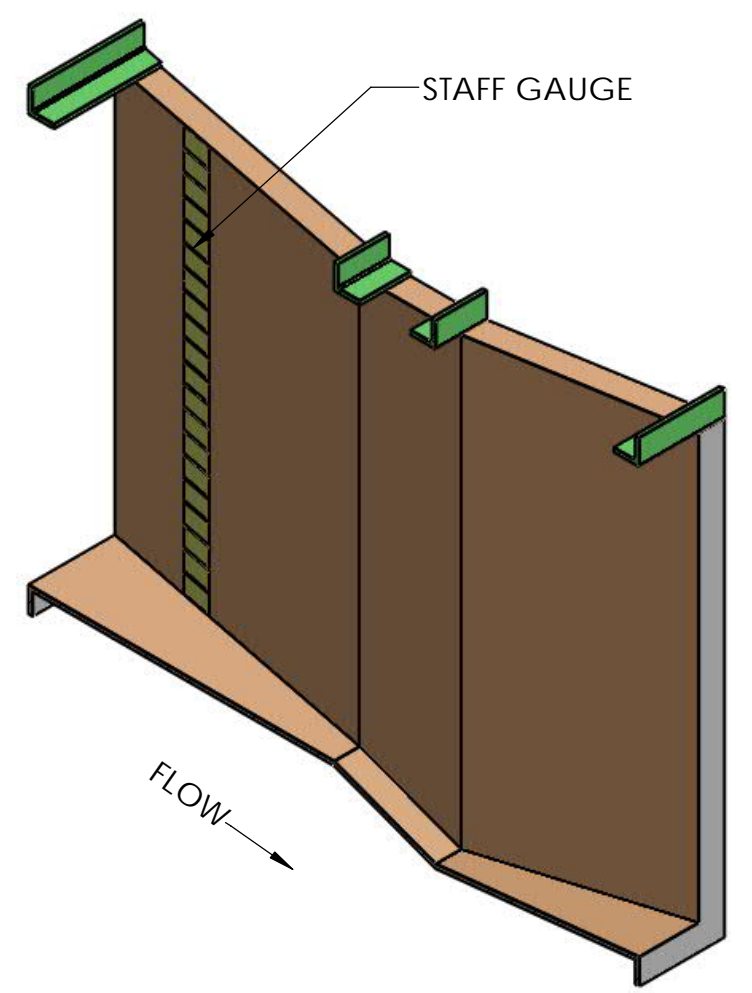
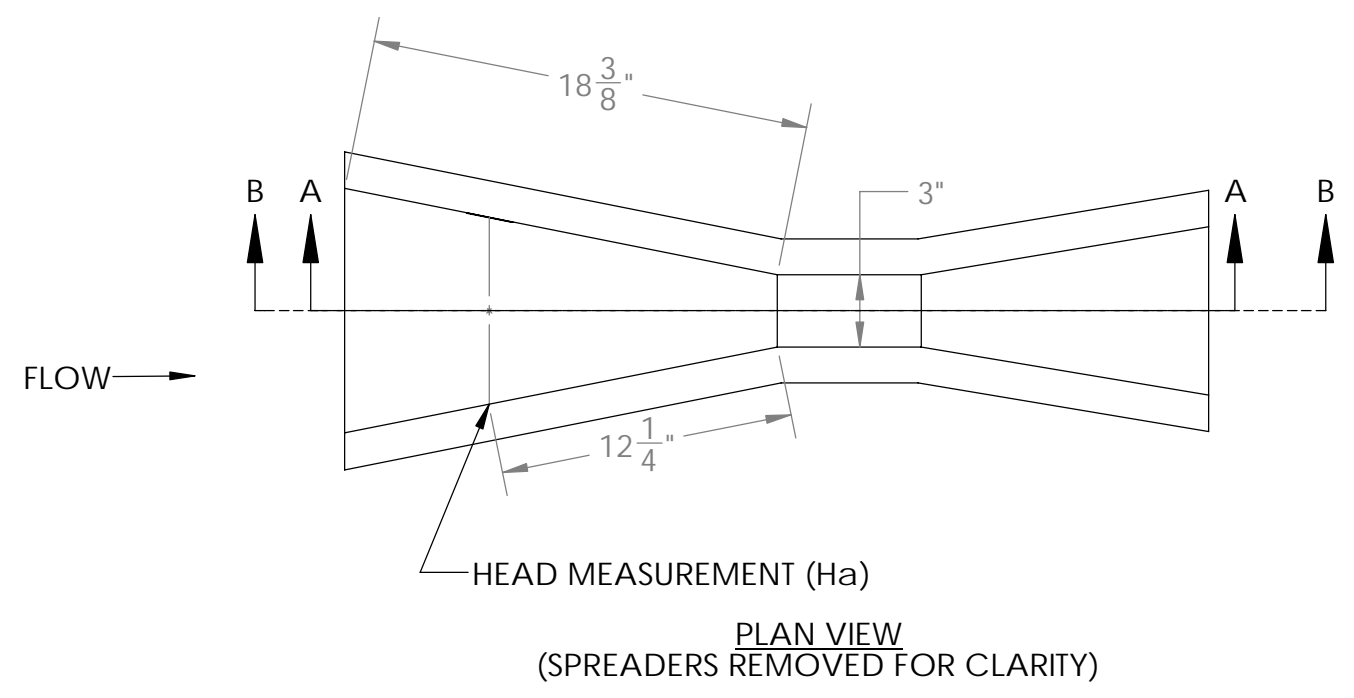

SECTION B-B

SECTION A-A

PROPRIETARY AND CONFIDENTIAL
THE INFORMATION CONTAINED IN THIS DRAWING IS THE SOLE PROPERTY OF Virtual Polymer Compounds, LLC. ANY REPRODUCTION IN PART OR AS A WHOLE WITHOUT THE WRITTEN PERMISSION OF Virtual Polymer Compounds, LLC IS PROHIBITED.

UNLESS OTHERWISE SPECIFIED:	NAME	DATE	 VPC 10478 Ridge Rd., Medina NY 14103 Toll Free: 888-290-9522 Phone: 585-735-9668
DIMENSIONS ARE IN INCHES TOLERANCES: FRACTIONAL ± ANGULAR: MACH ± BEND ± TWO PLACE DECIMAL ± THREE PLACE DECIMAL ±	DRAWN	LVR 8/6/2020	
INTERPRET GEOMETRIC TOLERANCING PER:	CHECKED		TITLE: 3 INCH PARSHALL FLUME
MATERIAL POLYESTER RESIN FINISH	ENG APPR.		Project: WITHOUT OPTIONS
DO NOT SCALE DRAWING	MFG APPR.		SIZE B
	Q.A.		DWG. NO.
	COMMENTS:		REV A
			SCALE: 1:8 Weight 25.16 SHEET 3 OF 5

8 7 6 5 4 3 2 1

8 7 6 5 4 3 2 1

D

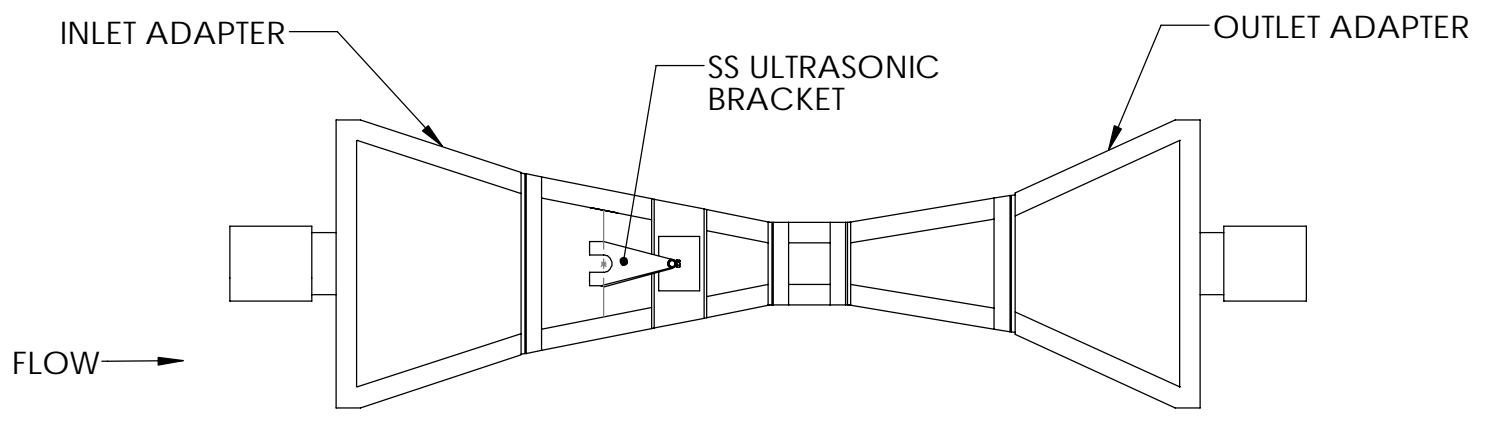

PLAN VIEW

PIPE COUPLER

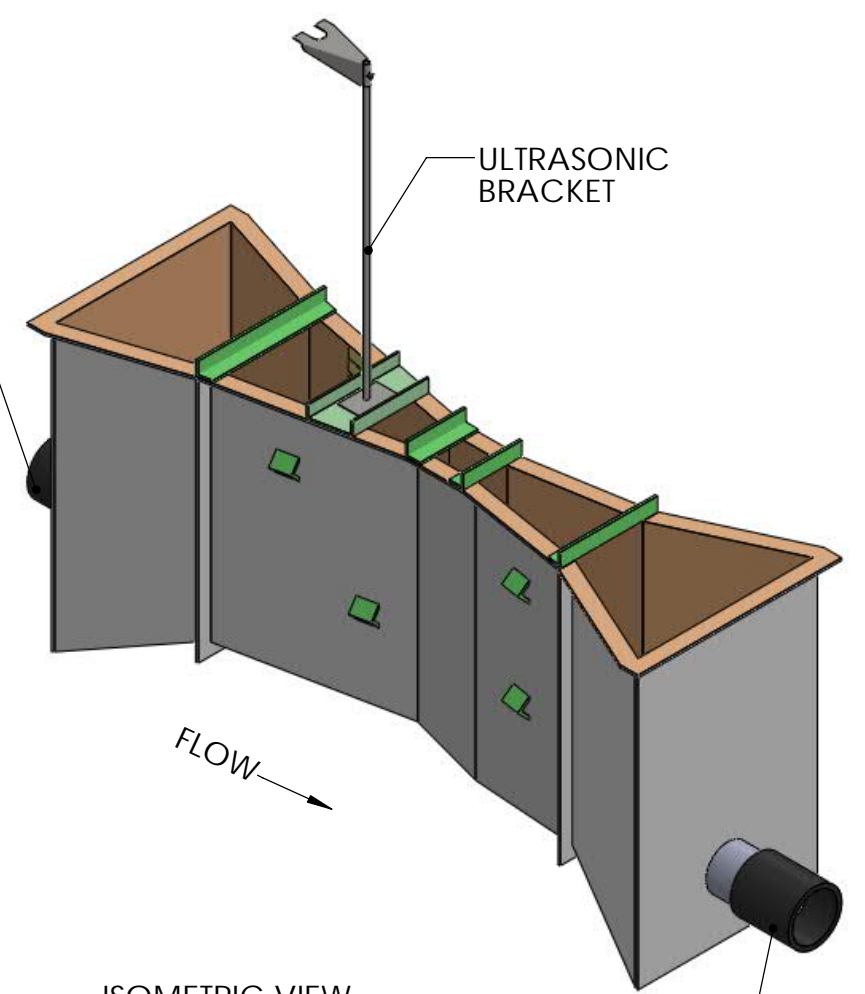

ISOMETRIC VIEW

C

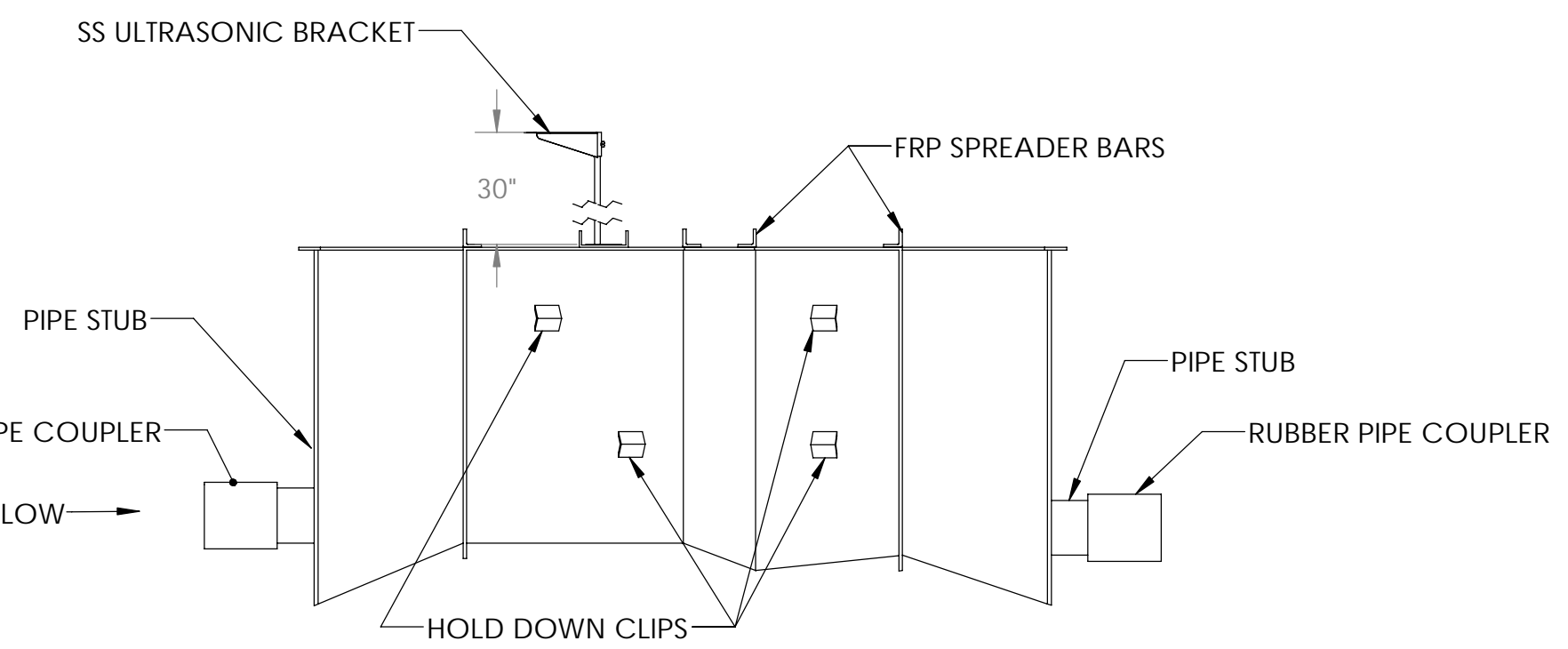

SIDE VIEW

B

B

A

A

PROPRIETARY AND CONFIDENTIAL
 THE INFORMATION CONTAINED IN THIS DRAWING IS THE SOLE PROPERTY OF Virtual Polymer Compounds, LLC. ANY REPRODUCTION IN PART OR AS A WHOLE WITHOUT THE WRITTEN PERMISSION OF Virtual Polymer Compounds, LLC IS PROHIBITED.

UNLESS OTHERWISE SPECIFIED:

DIMENSIONS ARE IN INCHES
 TOLERANCES:
 FRACTIONAL ±
 ANGULAR: MACH ± BEND ±
 TWO PLACE DECIMAL ±
 THREE PLACE DECIMAL ±

INTERPRET GEOMETRIC TOLERANCING PER:

MATERIAL
 POLYESTER RESIN
 FINISH

DO NOT SCALE DRAWING

	NAME	DATE
DRAWN	LVR	8/6/2020
CHECKED		
ENG APPR.		
MFG APPR.		
Q.A.		
COMMENTS:		
3rd ANGLE PROJECTION		

VPC 10478 Ridge Rd., Medina NY 14103
 FIBERGLASS Toll Free: 888-290-9522 Phone: 585-735-9668

TITLE: 3 INCH PARSHALL FLUME

Project: WITH OPTIONS

SIZE B	DWG. NO.	REV A
------------------	----------	----------

SCALE: 1:14 Weight 69.76 SHEET 4 OF 5

8 7 6 5 4 3 2 1

8 7 6 5 4 3 2 1

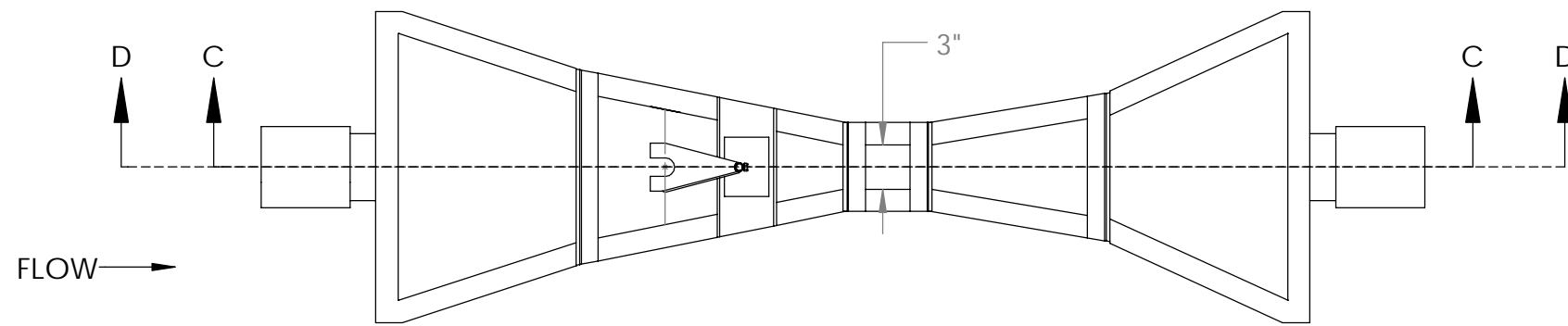

PLAN VIEW

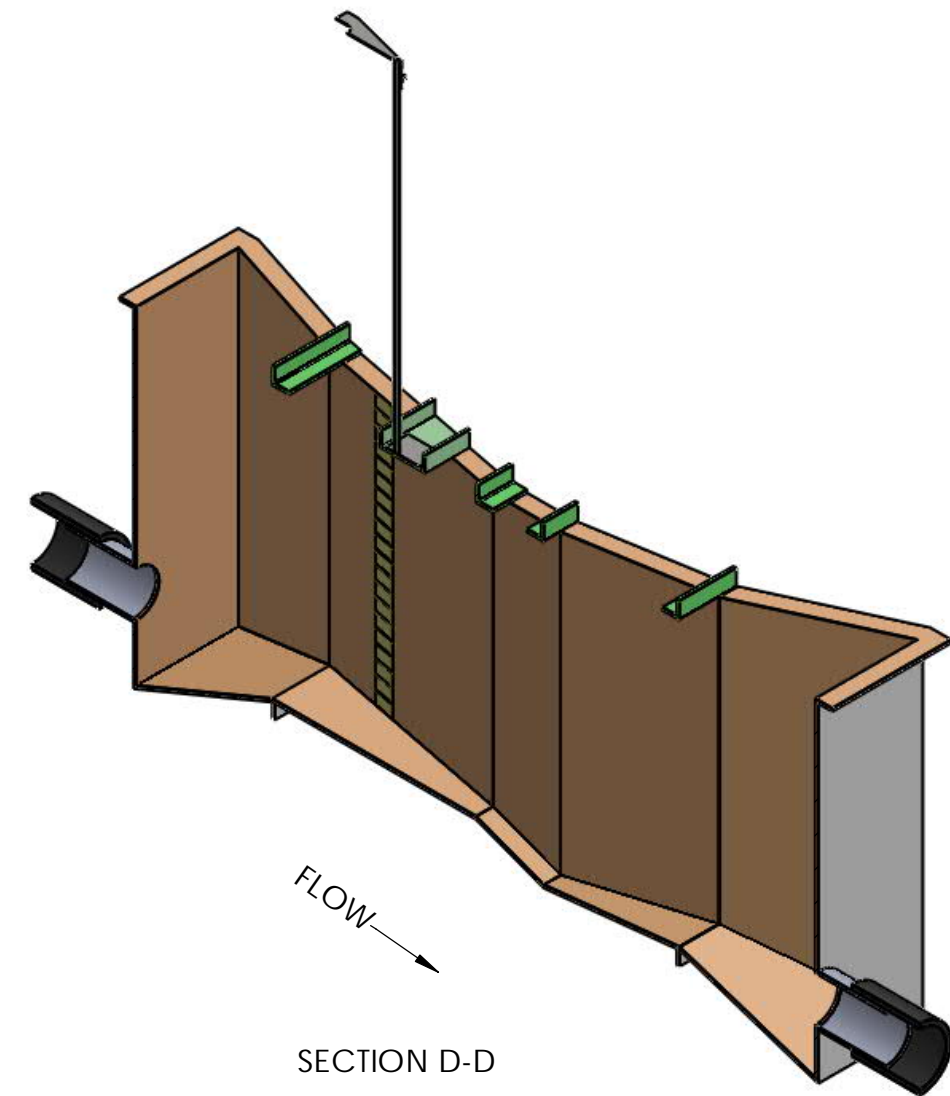

SECTION D-D

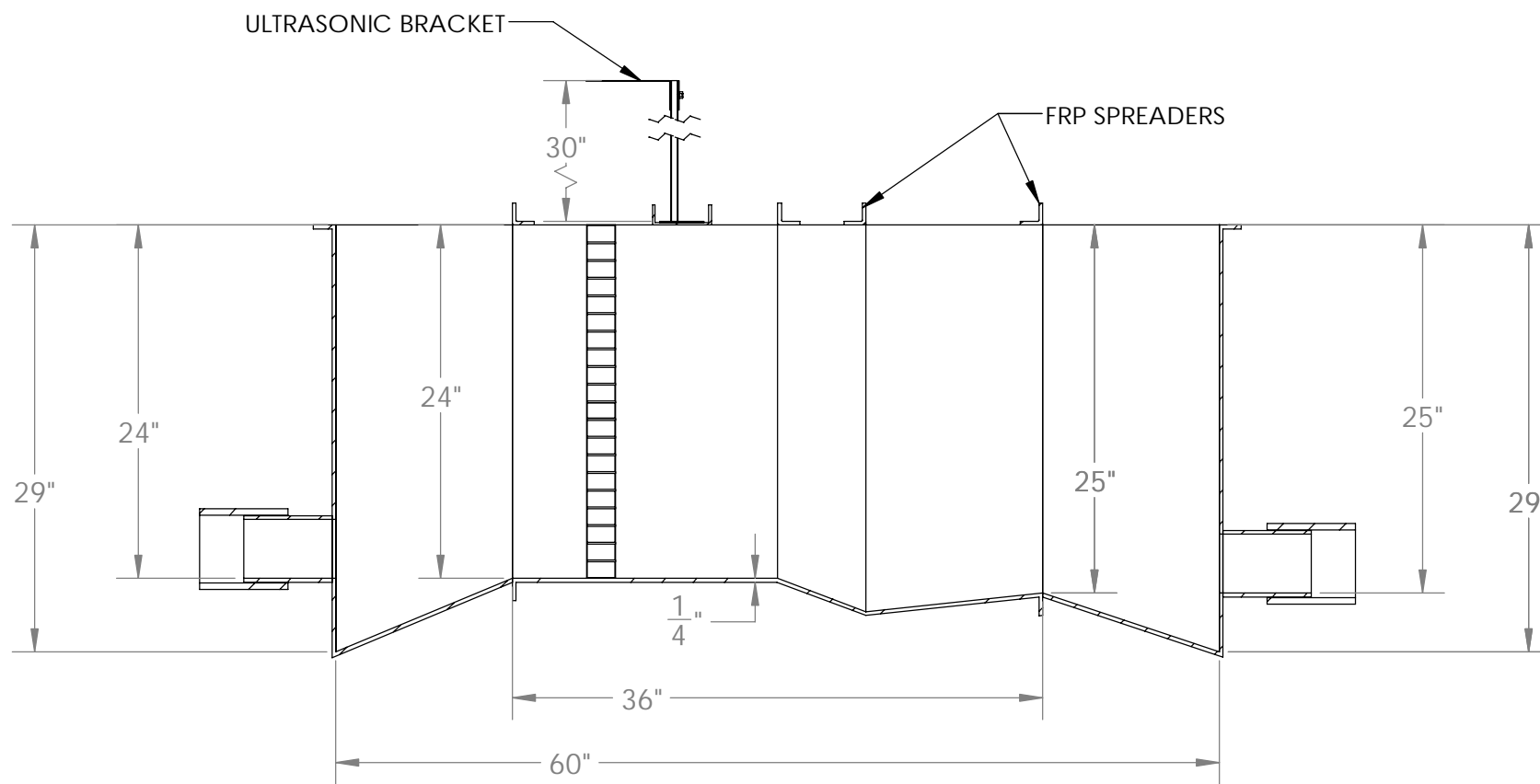

FLOW →

SECTION C-C

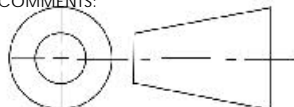
UNLESS OTHERWISE SPECIFIED:		NAME	DATE	 VPC 10478 Ridge Rd., Medina NY 14103 Toll Free: 888-290-9522 Phone: 585-735-9668
DIMENSIONS ARE IN INCHES TOLERANCES: FRACTIONAL ± ANGULAR: MACH ± BEND ± TWO PLACE DECIMAL ± THREE PLACE DECIMAL ±		DRAWN	LVR 8/6/2020	
INTERPRET GEOMETRIC TOLERANCING PER:		CHECKED		TITLE: 3 INCH PARSHALL FLUME
MATERIAL POLYESTER RESIN FINISH		ENG APPR.		Project: WITH OPTIONS
DO NOT SCALE DRAWING		MFG APPR.		SIZE B
PROPRIETARY AND CONFIDENTIAL THE INFORMATION CONTAINED IN THIS DRAWING IS THE SOLE PROPERTY OF Virtual Polymer Compounds, LLC. ANY REPRODUCTION IN PART OR AS A WHOLE WITHOUT THE WRITTEN PERMISSION OF Virtual Polymer Compounds, LLC IS PROHIBITED.		Q.A.		DWG. NO.
		COMMENTS:	 3rd ANGLE PROJECTION	REV A
				SCALE: 1:12 Weight 69.76 SHEET 5 OF 5

A

D

C

B

A

D

C

B

A

8 7 6 5 4 3 2 1