

8 7 6 5 4 3 2 1

D

D

C

C

B

B

A

A

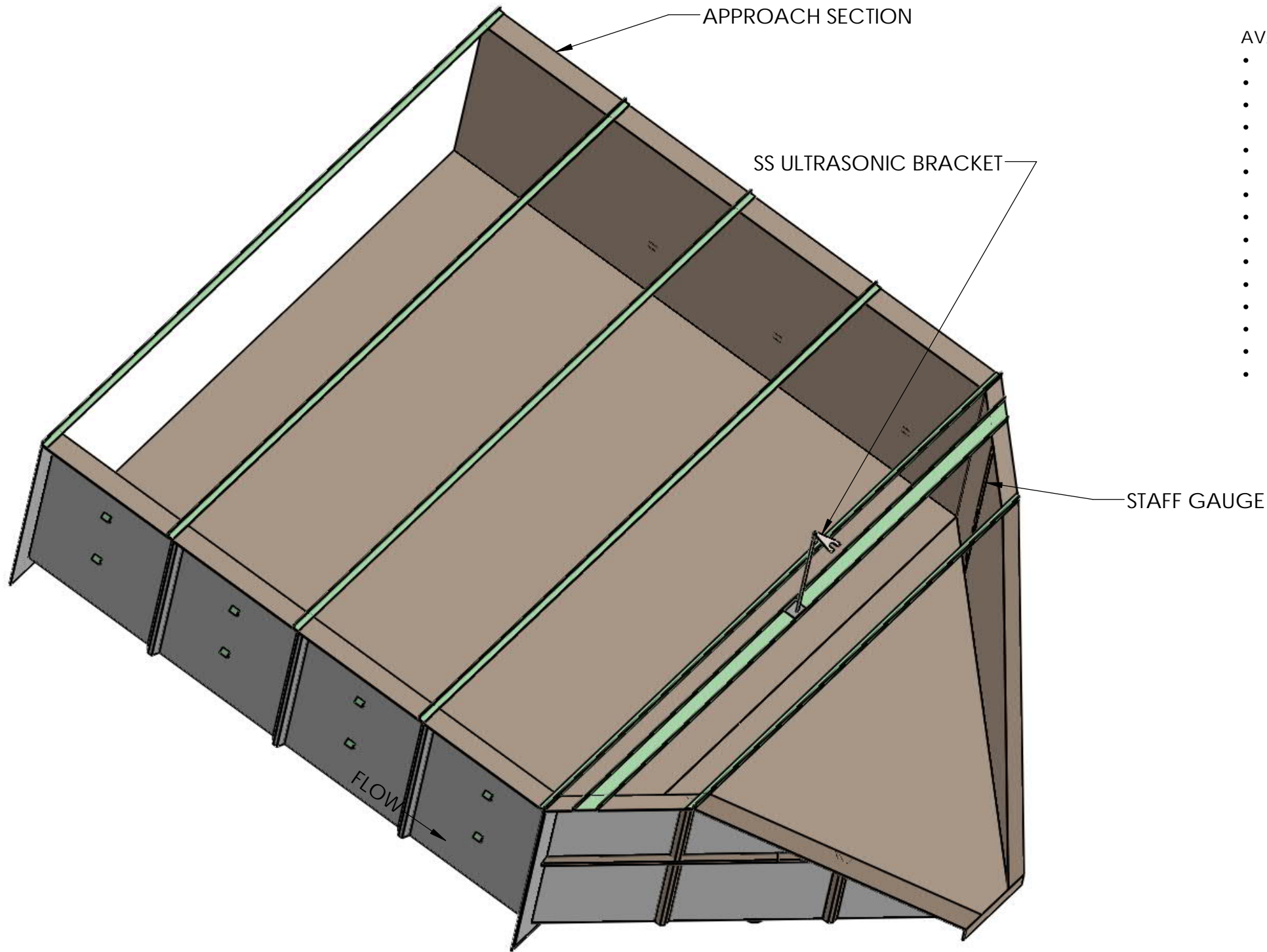

AVAILABLE OPTIONS:

- STAFF GAUGE (ENGLISH OR METRIC).
- STILLING WELL (INTEGRAL OR REMOTE).
- BUBBLER TUBE (SS 1/8" ID, INTEGRAL OR REMOVABLE).
- SAMPLER TUBE (SS 3/8" ID, INTEGRAL OR REMOVABLE).
- INLET APPROACH SECTIONS.
- PIPE STUBS.
- RUBBER PIPE COUPLERS W/ SS CLAMP BANDS.
- ADJUSTABLE SS ULTRASONIC BRACKET.
- PH PROBE CAVITY.
- WING WALLS.
- ENERGY ABSORBING RACKS. (FIXED OR REMOVABLE).
- STANDARD OR SPECIAL DEPTHS (INCLUDING SURGE BOXES).
- FLUME COVERS (GRATING, FIBER SHEETING, CLEAR POLYCARBONATE).
- SPECIAL DESIGN (TO MEET SPECIAL PROJECT NEEDS).
- STANDARD COLOR IS BEIGE (CUSTOM COLORS AVAILABLE).

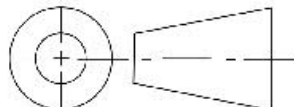
UNLESS OTHERWISE SPECIFIED:		NAME	DATE	 VPC FIBERGLASS 10478 Ridge Rd., Medina NY 14103 Toll Free: 888-290-9522 Phone: 585-735-9668				
DIMENSIONS ARE IN INCHES TOLERANCES: FRACTIONAL ± ANGULAR: MACH ± BEND ± TWO PLACE DECIMAL ± THREE PLACE DECIMAL ±		DRAWN	LVR		1/4/2021			
INTERPRET GEOMETRIC TOLERANCING PER:		CHECKED			TITLE:	4.0HL FLUME		
MATERIAL POLYESTER RESIN FINISH		ENG APPR.			Project:	WITH OPTIONS		
DO NOT SCALE DRAWING		MFG APPR.			SIZE	DWG. NO.	REV	
3rd ANGLE PROJECTION		Q.A.			B		A	
					SCALE: 1:28	Weight 796.96	SHEET 1 OF 5	

PROPRIETARY AND CONFIDENTIAL
 THE INFORMATION CONTAINED IN THIS DRAWING IS THE SOLE PROPERTY OF VIRTUAL POLYMER COMPOUNDS, LLC. ANY REPRODUCTION IN PART OR AS A WHOLE WITHOUT THE WRITTEN PERMISSION OF VIRTUAL POLYMER COMPOUNDS, LLC IS PROHIBITED.

8 7 6 5 4 3 2 1

8 7 6 5 4 3 2 1

D

C

B

A

D

C

B

A

HEAD MEASUREMENT
LOCATION

FLOW →

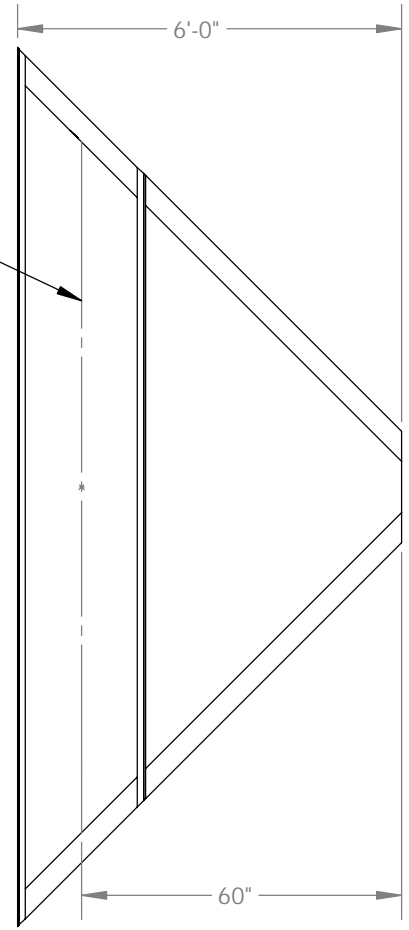

PLAN VIEW

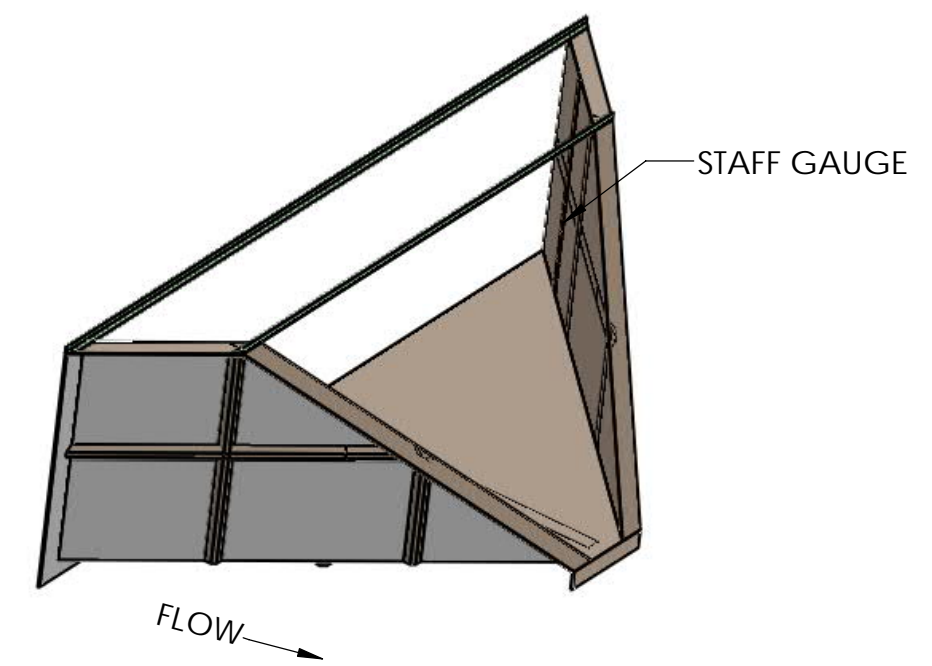

ISOMETRIC VIEW

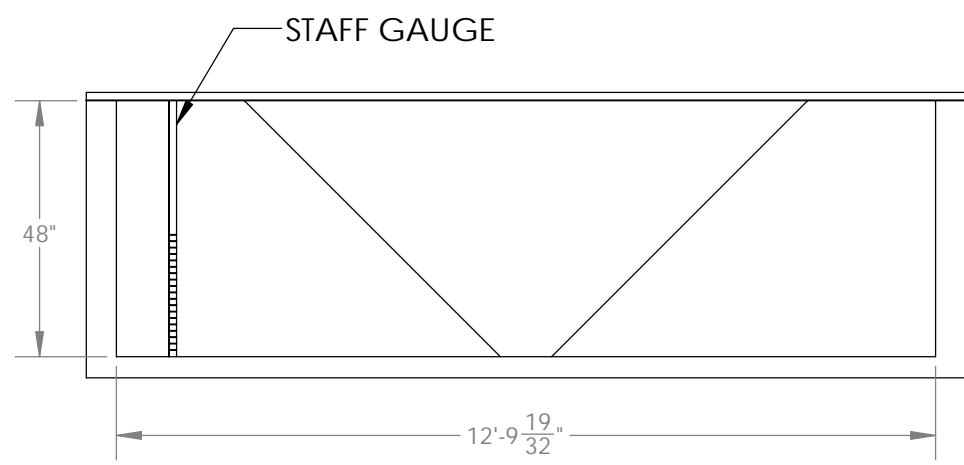

END VIEW
(LOOKING DOWN STREAM)

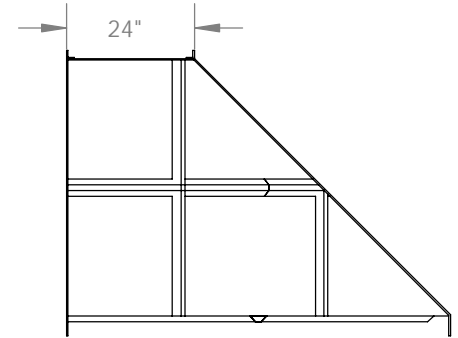

FLOW →

SIDE VIEW

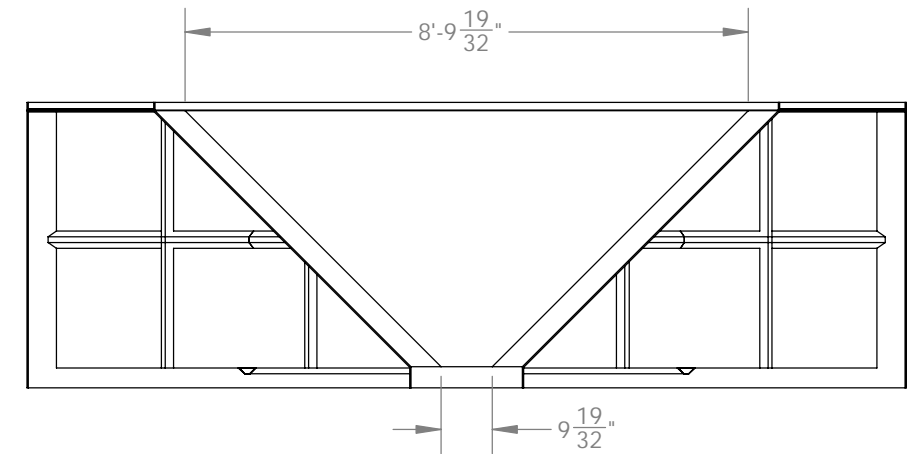

END VIEW
(LOOKING UP STREAM)

PROPRIETARY AND CONFIDENTIAL
THE INFORMATION CONTAINED IN THIS
DRAWING IS THE SOLE PROPERTY OF
Virtual Polymer Compounds, LLC. ANY
REPRODUCTION IN PART OR AS A WHOLE
WITHOUT THE WRITTEN PERMISSION OF
Virtual Polymer Compounds, LLC IS
PROHIBITED.

UNLESS OTHERWISE SPECIFIED:
DIMENSIONS ARE IN INCHES
TOLERANCES:
FRACTIONAL ±
ANGULAR: MACH ± BEND ±
TWO PLACE DECIMAL ±
THREE PLACE DECIMAL ±
INTERPRET GEOMETRIC
TOLERANCING PER:
MATERIAL
POLYESTER RESIN
FINISH
DO NOT SCALE DRAWING

NAME	DATE
DRAWN LVR	1/4/2021
CHECKED	
ENG APPR.	
MFG APPR.	
Q.A.	

COMMENTS:
3rd ANGLE PROJECTION

VPC 10478 Ridge Rd.,
Medina NY 14103
Toll Free: 888-290-9522
Phone: 585-735-9668

FIBERGLASS

TITLE: 4.0HL FLUME

Project: NO OPTIONS

SIZE B	DWG. NO.	REV A
------------------	----------	----------

SCALE: 1:36 Weight 210.23 SHEET 2 OF 5

8 7 6 5 4 3 2 1

D

C

B

A

FLOW →

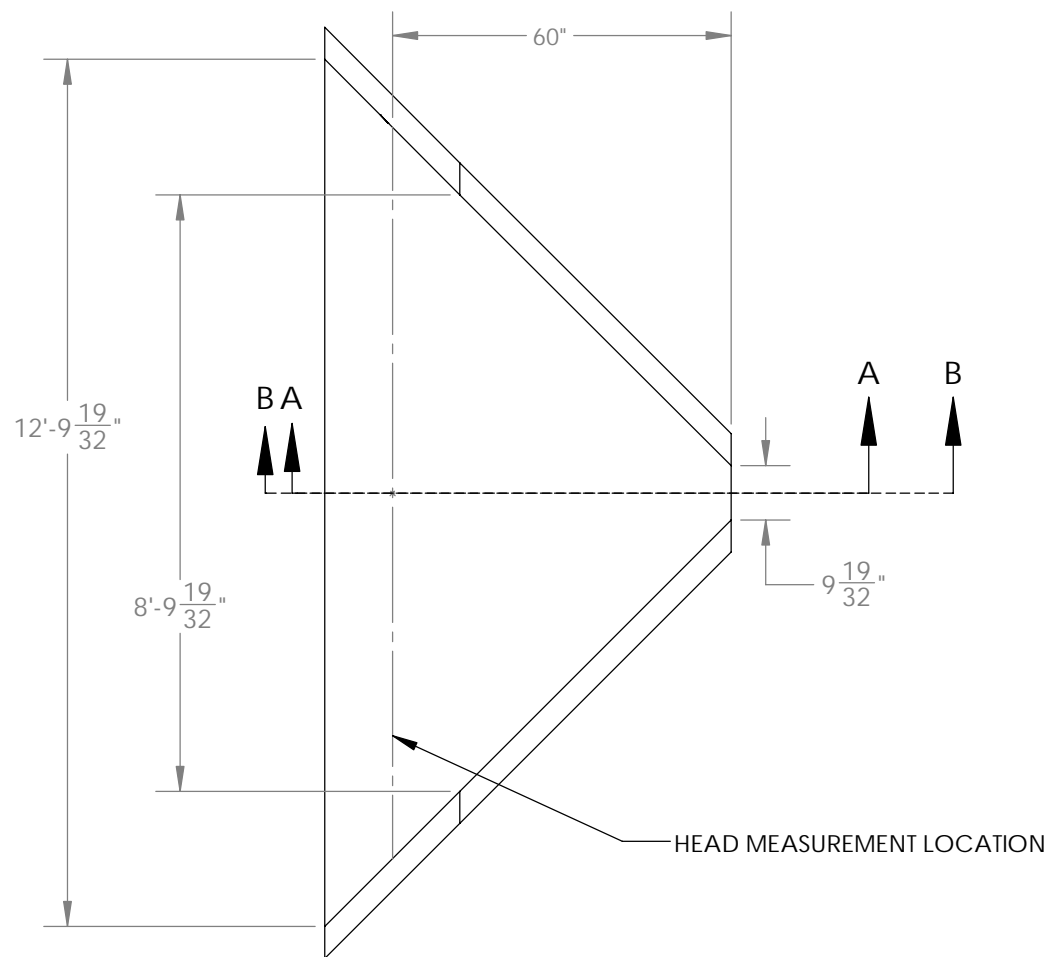

PLAN VIEW
(SPREADER BARS REMOVED FOR CLARITY)

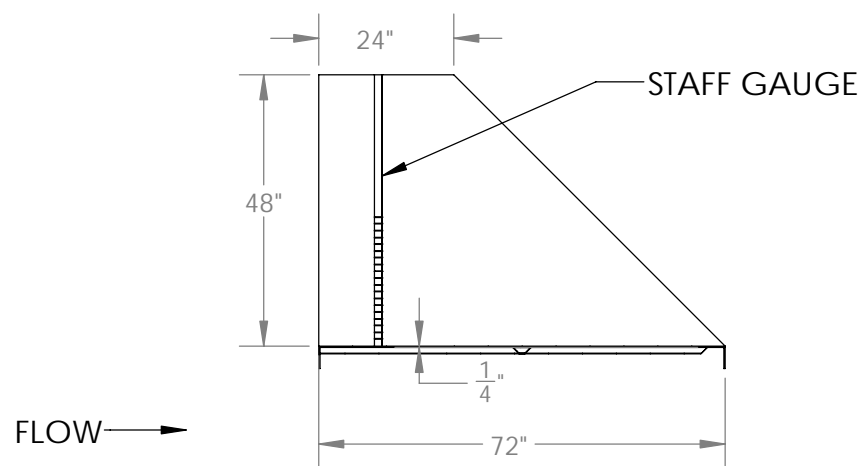

SECTION A-A

STAFF GAUGE

FLOW →

SECTION B-B

PROPRIETARY AND CONFIDENTIAL
THE INFORMATION CONTAINED IN THIS DRAWING IS THE SOLE PROPERTY OF Virtual Polymer Compounds, LLC. ANY REPRODUCTION IN PART OR AS A WHOLE WITHOUT THE WRITTEN PERMISSION OF Virtual Polymer Compounds, LLC IS PROHIBITED.

UNLESS OTHERWISE SPECIFIED:	NAME	DATE
DIMENSIONS ARE IN INCHES TOLERANCES: FRACTIONAL ± ANGULAR: MACH ± BEND ± TWO PLACE DECIMAL ± THREE PLACE DECIMAL ±	DRAWN LVR	1/4/2021
INTERPRET GEOMETRIC TOLERANCING PER:	CHECKED	
MATERIAL POLYESTER RESIN FINISH	ENG APPR.	
DO NOT SCALE DRAWING	MFG APPR.	

Q.A.	
COMMENTS:	
3rd ANGLE PROJECTION	

		10478 Ridge Rd., Medina NY 14103 Toll Free: 888-290-9522 Phone: 585-735-9668	
TITLE: 4.0HL FLUME			
Project: NO OPTIONS			
SIZE B	DWG. NO.	REV A	
SCALE: 1:34	Weight 210.23	SHEET 3 OF 5	

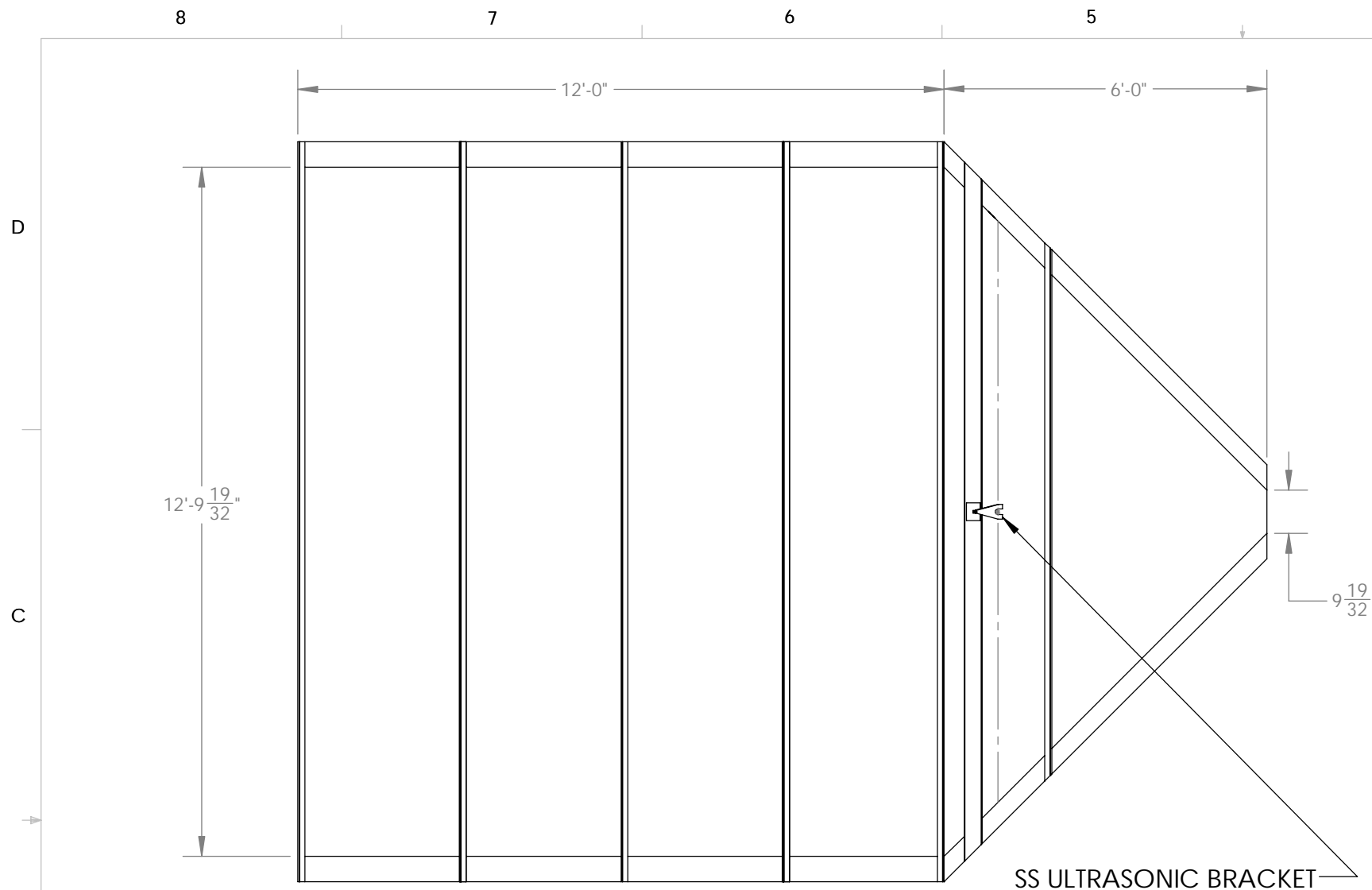

PLAN VIEW

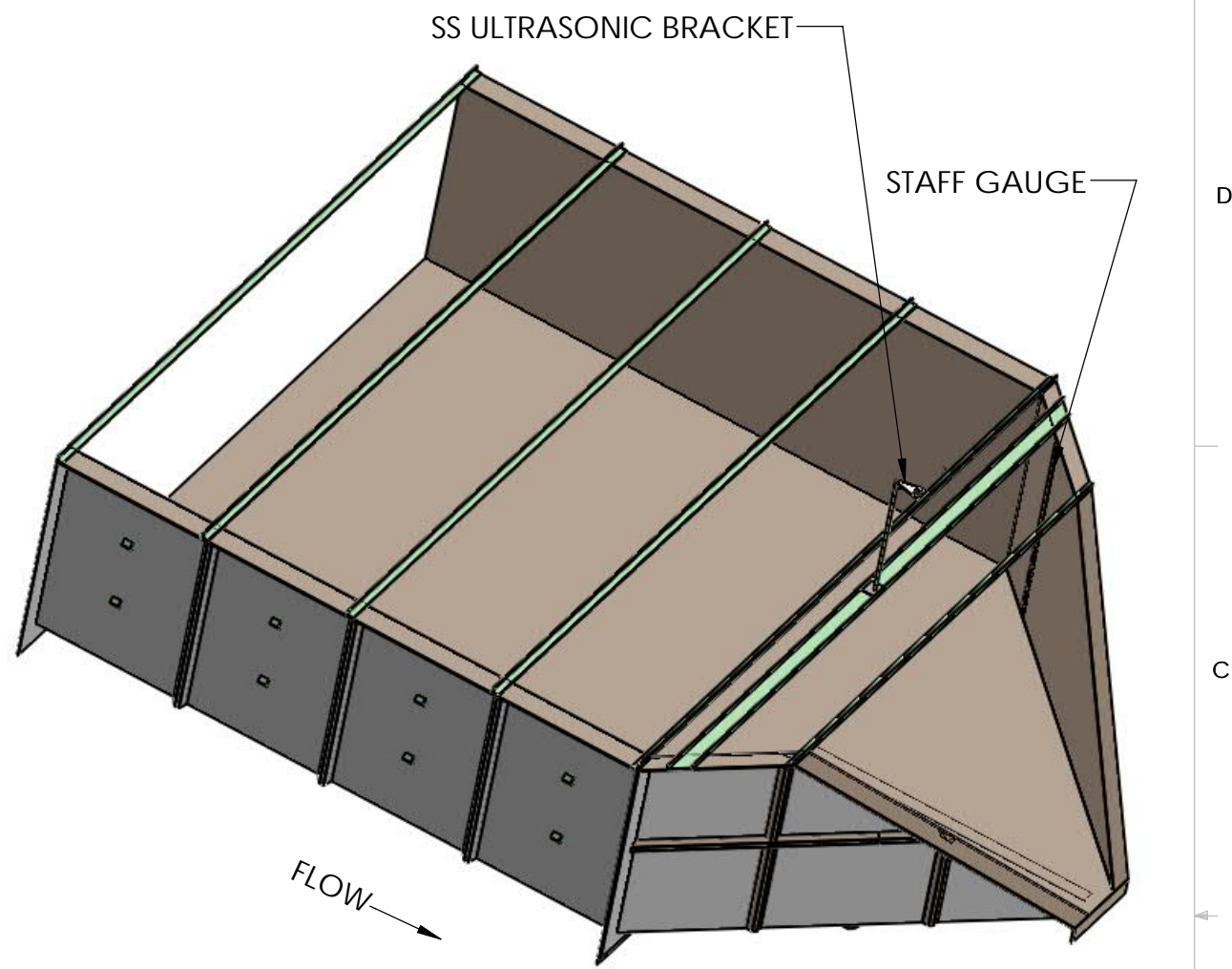

ISOMETRIC VIEW
SCALE: 1:38

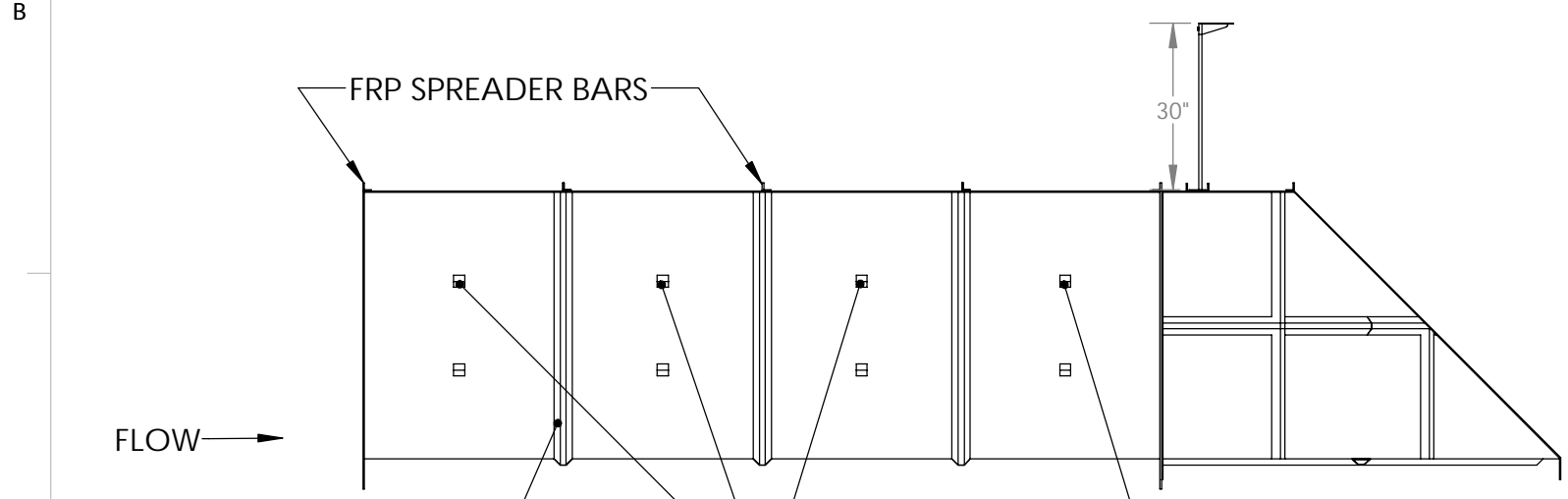

SIDE VIEW

PROPRIETARY AND CONFIDENTIAL
THE INFORMATION CONTAINED IN THIS DRAWING IS THE SOLE PROPERTY OF Virtual Polymer Compounds, LLC. ANY REPRODUCTION IN PART OR AS A WHOLE WITHOUT THE WRITTEN PERMISSION OF Virtual Polymer Compounds, LLC IS PROHIBITED.

UNLESS OTHERWISE SPECIFIED:

DIMENSIONS ARE IN INCHES
TOLERANCES:
FRACTIONAL ±
ANGULAR: MACH ± BEND ±
TWO PLACE DECIMAL ±
THREE PLACE DECIMAL ±

INTERPRET GEOMETRIC TOLERANCING PER:

MATERIAL
POLYESTER RESIN
FINISH

DO NOT SCALE DRAWING

NAME	DATE
DRAWN LVR	1/4/2021
CHECKED	
ENG APPR.	
MFG APPR.	
Q.A.	

COMMENTS:

3rd ANGLE PROJECTION

VPC 10478 Ridge Rd., Medina NY 14103
Toll Free: 888-290-9522
FIBERGLASS Phone: 585-735-9668

TITLE: 4.0HL FLUME

Project: WITH OPTIONS

SIZE B	DWG. NO.	REV A
--------	----------	-------

SCALE: 1:34 Weight 796.96 SHEET 4 OF 5

8 7 6 5 4 3 2 1

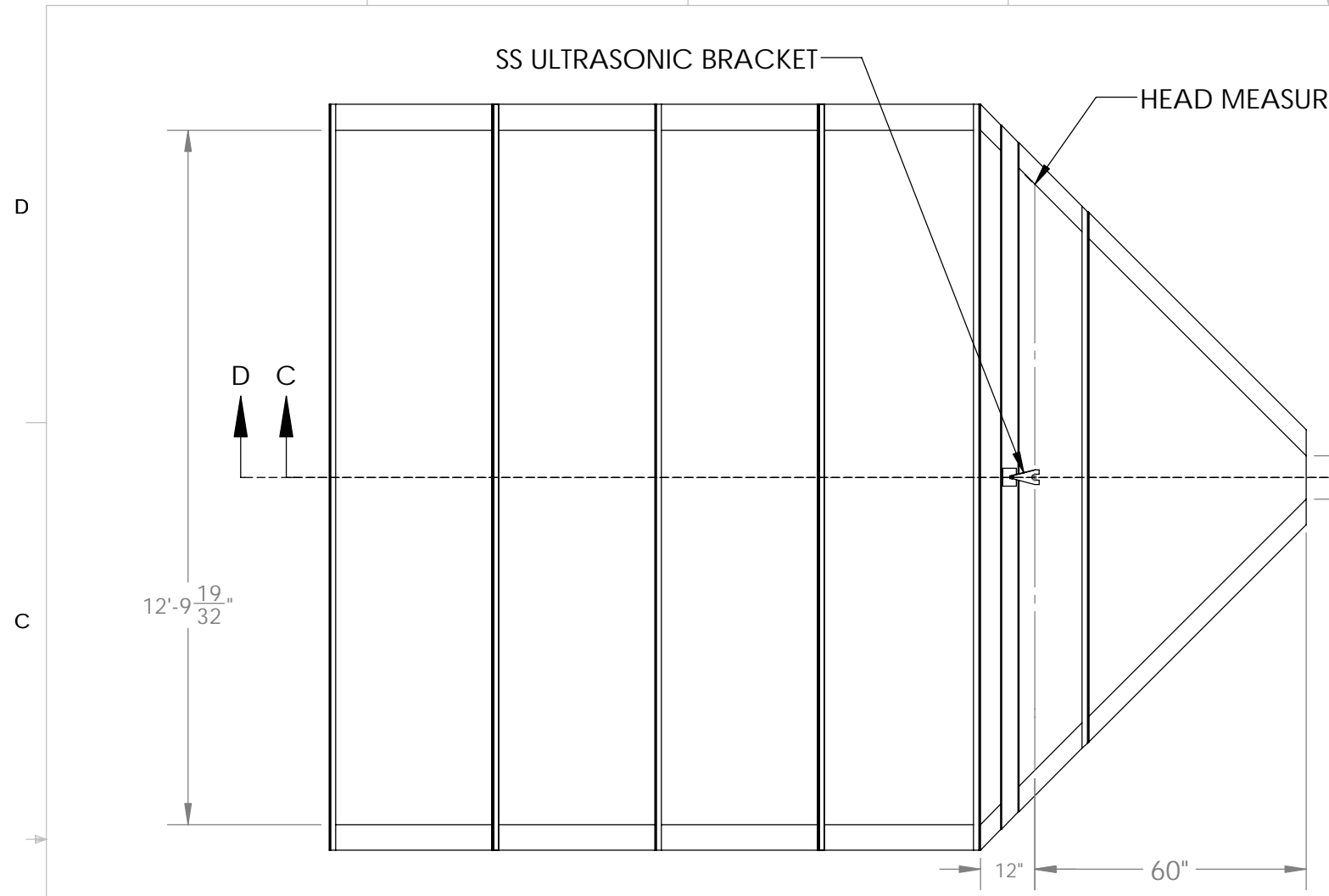

PLAN VIEW

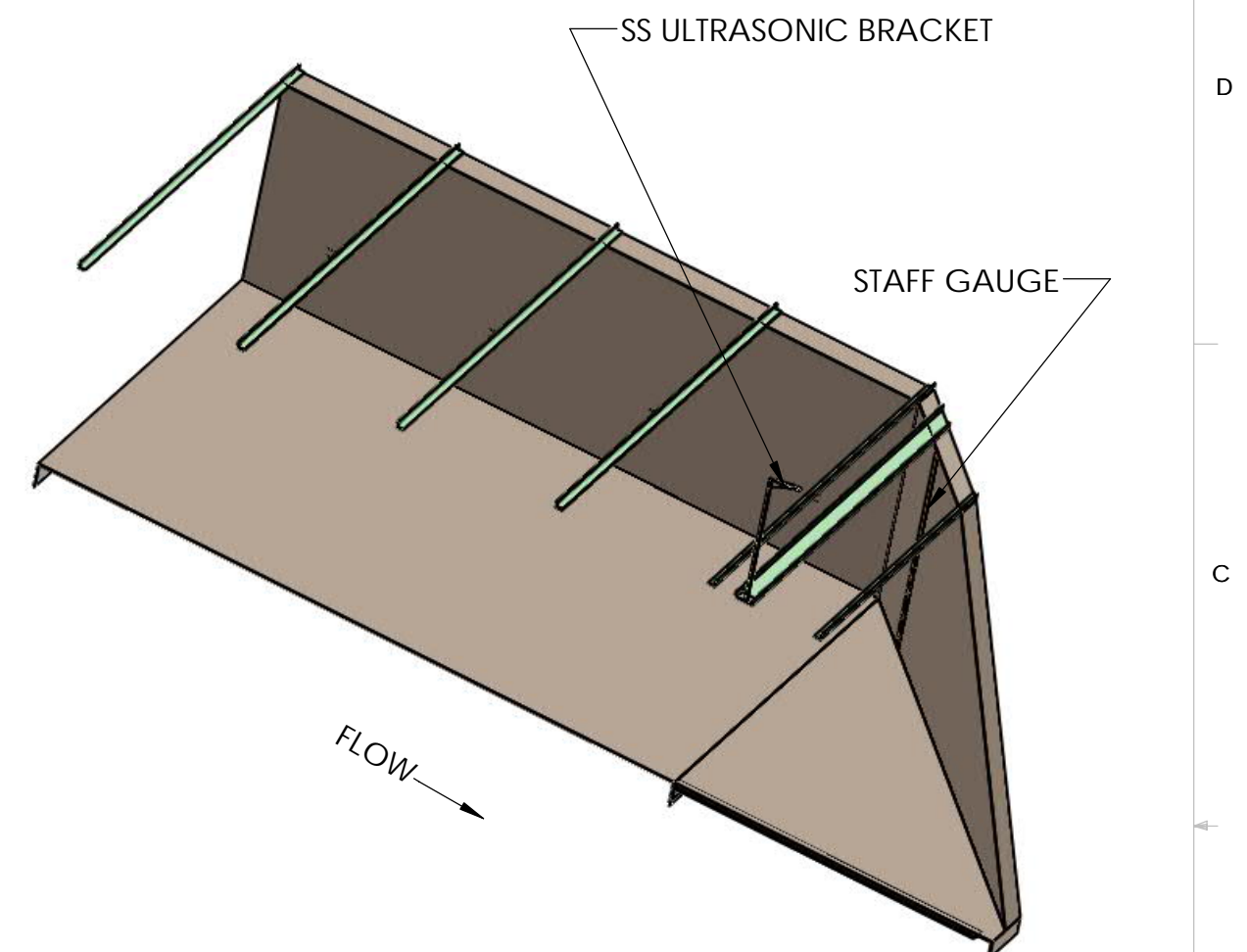

SECTION D-D

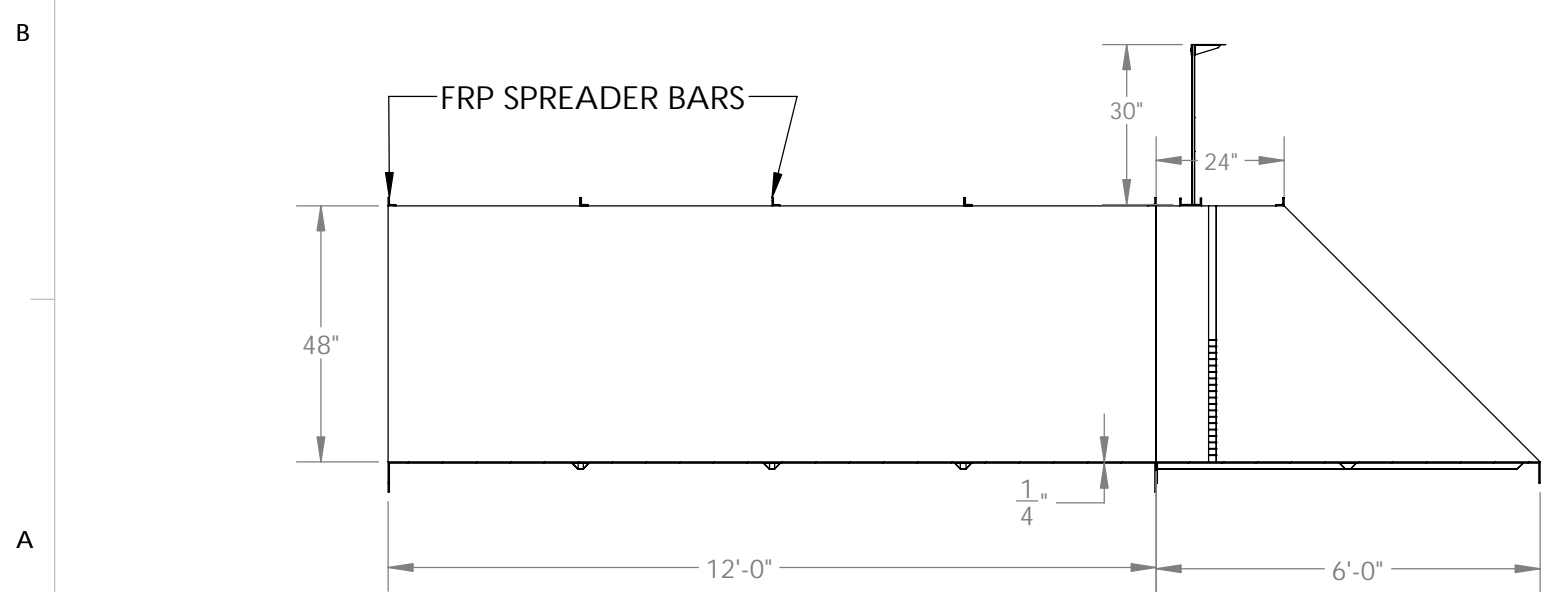

SECTION C-C

PROPRIETARY AND CONFIDENTIAL
 THE INFORMATION CONTAINED IN THIS DRAWING IS THE SOLE PROPERTY OF Virtual Polymer Compounds, LLC. ANY REPRODUCTION IN PART OR AS A WHOLE WITHOUT THE WRITTEN PERMISSION OF Virtual Polymer Compounds, LLC IS PROHIBITED.

UNLESS OTHERWISE SPECIFIED:	NAME	DATE	<p>10478 Ridge Rd., Medina NY 14103 Toll Free: 888-290-9522 Phone: 585-735-9668</p>	
DIMENSIONS ARE IN INCHES	DRAWN	LVR		1/4/2021
TOLERANCES:	CHECKED			
FRACTIONAL ±	ENG APPR.			
ANGULAR: MACH ±	MFG APPR.			
TWO PLACE DECIMAL ±	Q.A.			
THREE PLACE DECIMAL ±	COMMENTS:			
INTERPRET GEOMETRIC TOLERANCING PER:			TITLE: 4.0HL FLUME	
MATERIAL: POLYESTER RESIN			Project: WITH OPTIONS	
FINISH:			SIZE: B	
DO NOT SCALE DRAWING			DWG. NO.	
			REV: A	
			SCALE: 1:36 Weight 796.96 SHEET 5 OF 5	

8 7 6 5 4 3 2 1