

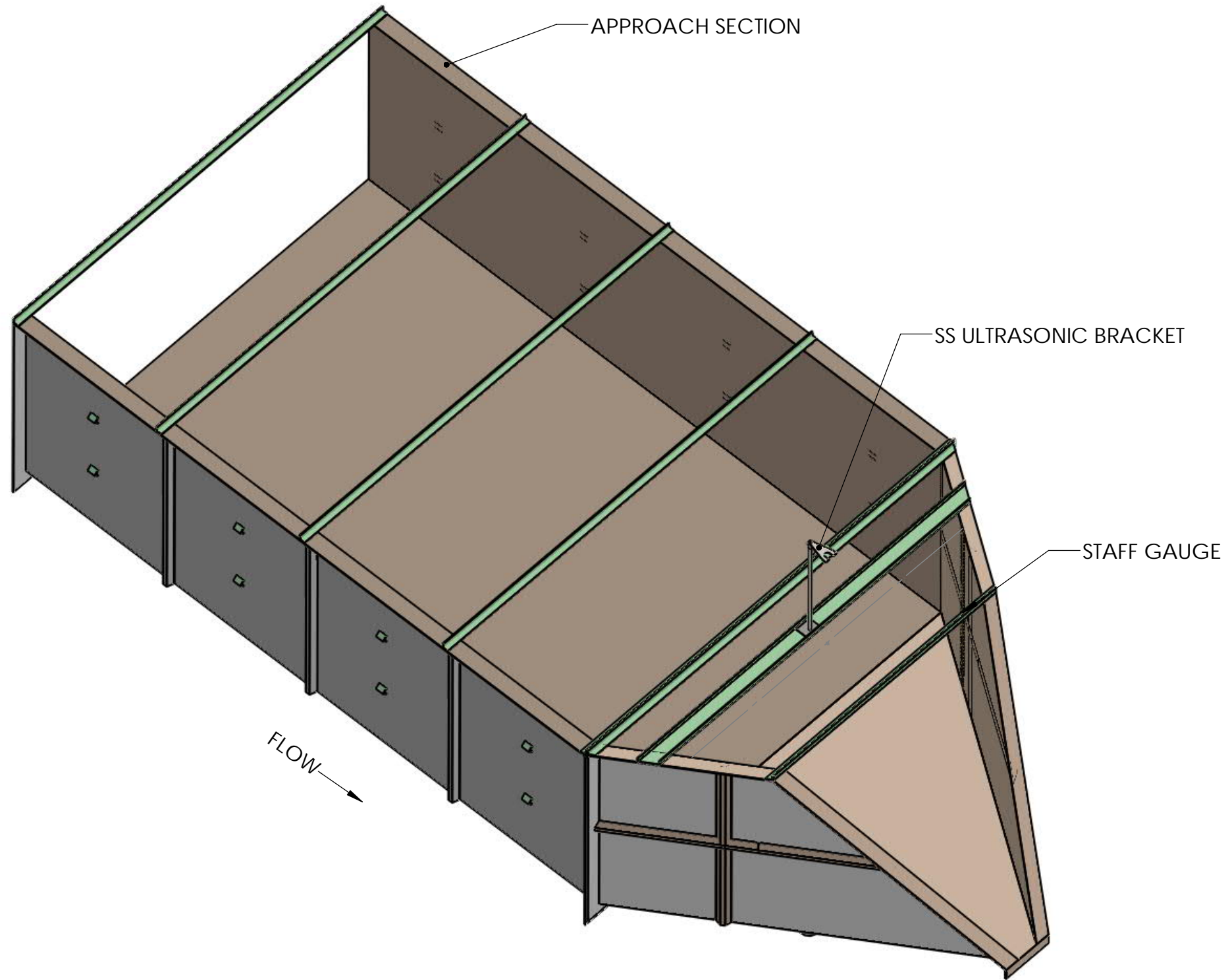

8 7 6 5 4 3 2 1

D
C
B
A



- AVAILABLE OPTIONS:
- STAFF GAUGE (ENGLISH OR METRIC).
 - STILLING WELL (INTEGRAL OR REMOTE).
 - BUBBLER TUBE (SS 1/8" ID, INTEGRAL OR REMOVABLE).
 - SAMPLER TUBE (SS 3/8" ID, INTEGRAL OR REMOVABLE).
 - INLET APPROACH SECTIONS.
 - PIPE STUBS.
 - RUBBER PIPE COUPLERS W/ SS CLAMP BANDS.
 - ADJUSTABLE SS ULTRASONIC BRACKET.
 - PH PROBE CAVITY.
 - WING WALLS.
 - ENERGY ABSORBING RACKS. (FIXED OR REMOVABLE).
 - STANDARD OR SPECIAL DEPTHS (INCLUDING SURGE BOXES).
 - FLUME COVERS (GRATING, FIBER SHEETING, CLEAR POLYCARBONATE).
 - SPECIAL DESIGN (TO MEET SPECIAL PROJECT NEEDS).
 - STANDARD COLOR IS BEIGE (CUSTOM COLORS AVAILABLE).

FLOW →

UNLESS OTHERWISE SPECIFIED:		NAME	DATE	 VPC FIBERGLASS 10478 Ridge Rd., Medina NY 14103 Toll Free: 888-290-9522 Phone: 585-735-9668	
DIMENSIONS ARE IN INCHES		DRAWN	LVR		9/4/2020
TOLERANCES:		CHECKED			
FRACTIONAL ±		ENG APPR.			
ANGULAR: MACH ± BEND ±		MFG APPR.			
TWO PLACE DECIMAL ±		Q.A.			
THREE PLACE DECIMAL ±				TITLE: 4.5H FLUME	
INTERPRET GEOMETRIC TOLERANCING PER:				Project: WITH OPTIONS	
MATERIAL: POLYESTER RESIN				SIZE: B	
FINISH:				DWG. NO.:	
DO NOT SCALE DRAWING		3rd ANGLE PROJECTION		REV: A	
				SCALE: 1:26 Weight 695.39 SHEET 1 OF 5	

PROPRIETARY AND CONFIDENTIAL
 THE INFORMATION CONTAINED IN THIS DRAWING IS THE SOLE PROPERTY OF VIRTUAL POLYMER COMPOUNDS, LLC. ANY REPRODUCTION IN PART OR AS A WHOLE WITHOUT THE WRITTEN PERMISSION OF VIRTUAL POLYMER COMPOUNDS, LLC IS PROHIBITED.

8 7 6 5 4 3 2 1

8 7 6 5 4 3 2 1

D

C

B

A

D

C

B

A

HEAD MEASUREMENT LOCATION

FLOW →

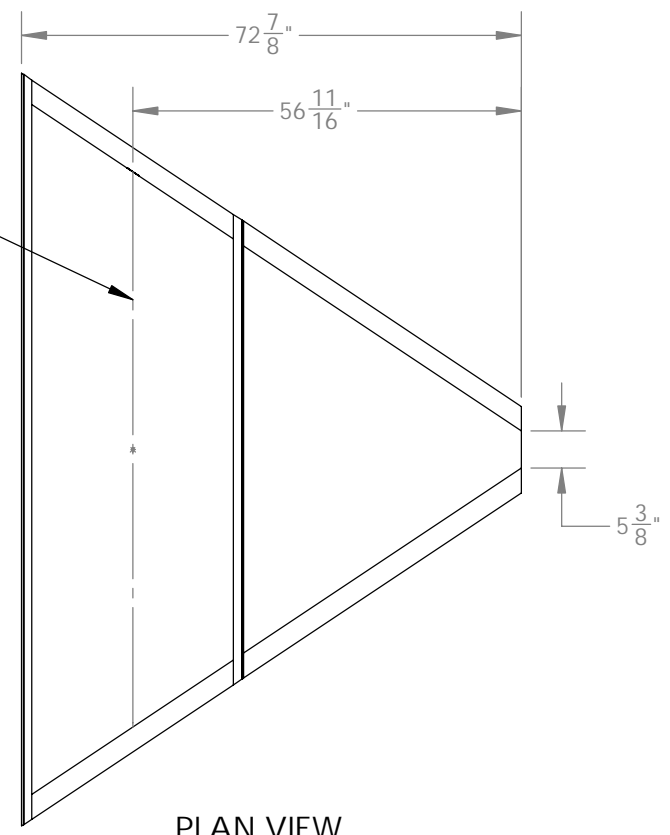

PLAN VIEW

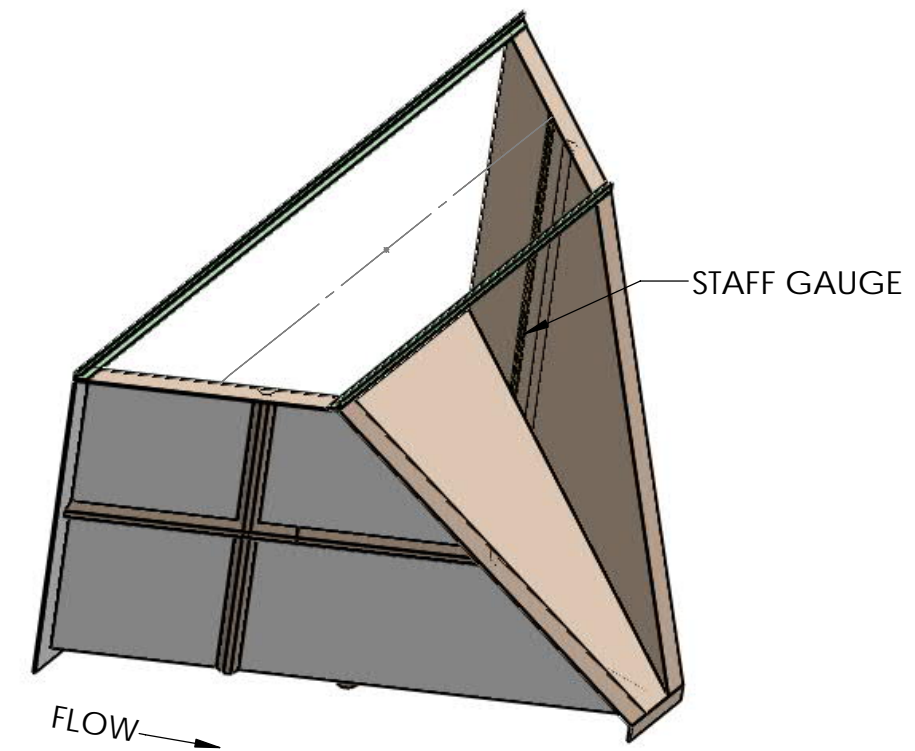

ISOMETRIC VIEW

STAFF GAUGE

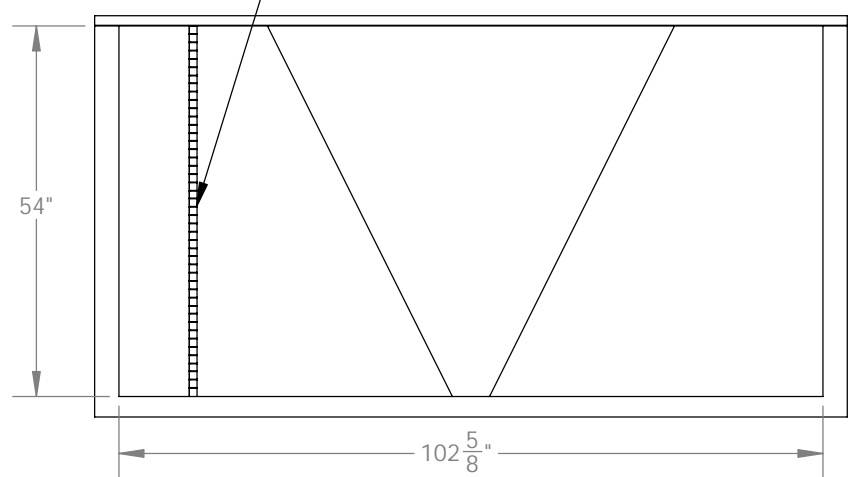

END VIEW
(LOOKING DOWN STREAM)

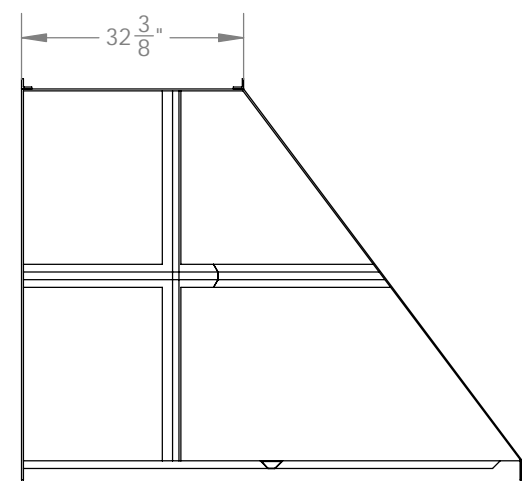

SIDE VIEW

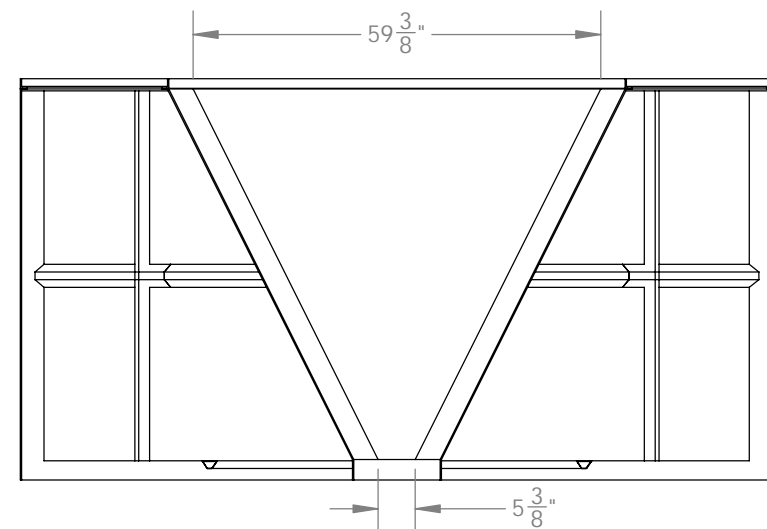

END VIEW
(LOOKING UP STREAM)

UNLESS OTHERWISE SPECIFIED:

DIMENSIONS ARE IN INCHES
TOLERANCES:
FRACTIONAL ±
ANGULAR: MACH ± BEND ±
TWO PLACE DECIMAL ±
THREE PLACE DECIMAL ±

INTERPRET GEOMETRIC
TOLERANCING PER:
MATERIAL
POLYESTER RESIN
FINISH

DO NOT SCALE DRAWING

NAME DATE

DRAWN LVR 9/4/2020

CHECKED

ENG APPR.

MFG APPR.

Q.A.

COMMENTS:

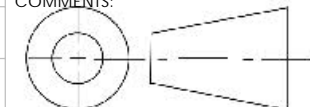

3rd ANGLE PROJECTION

VPC 10478 Ridge Rd.,
Medina NY 14103
Toll Free: 888-290-9522
FIBERGLASS Phone: 585-735-9668

TITLE: 4.5H FLUME

Project: NO OPTIONS

SIZE B	DWG. NO.	REV A
------------------	----------	----------

SCALE: 1:28 Weight 172.88 SHEET 2 OF 5

PROPRIETARY AND CONFIDENTIAL
THE INFORMATION CONTAINED IN THIS
DRAWING IS THE SOLE PROPERTY OF
Virtual Polymer Compounds, LLC. ANY
REPRODUCTION IN PART OR AS A WHOLE
WITHOUT THE WRITTEN PERMISSION OF
Virtual Polymer Compounds, LLC IS
PROHIBITED.

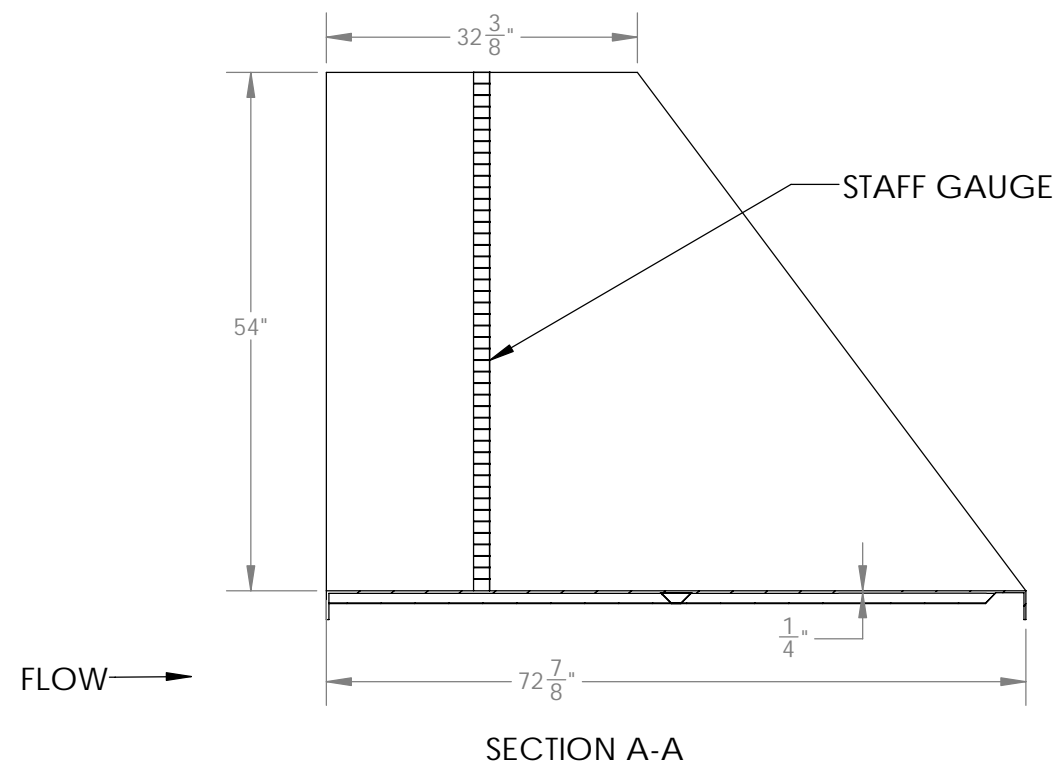
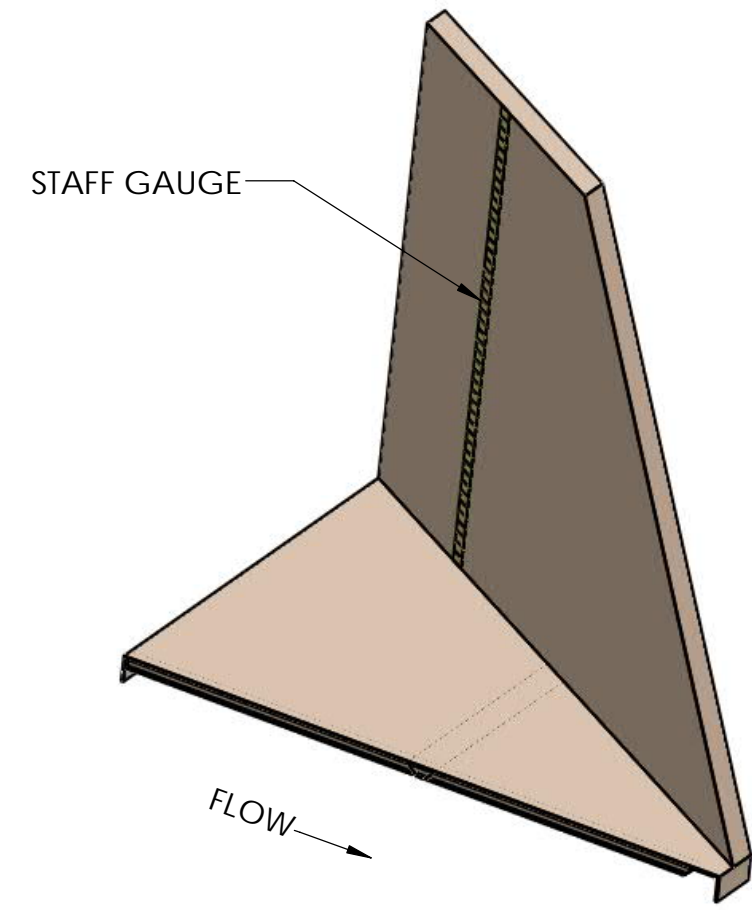
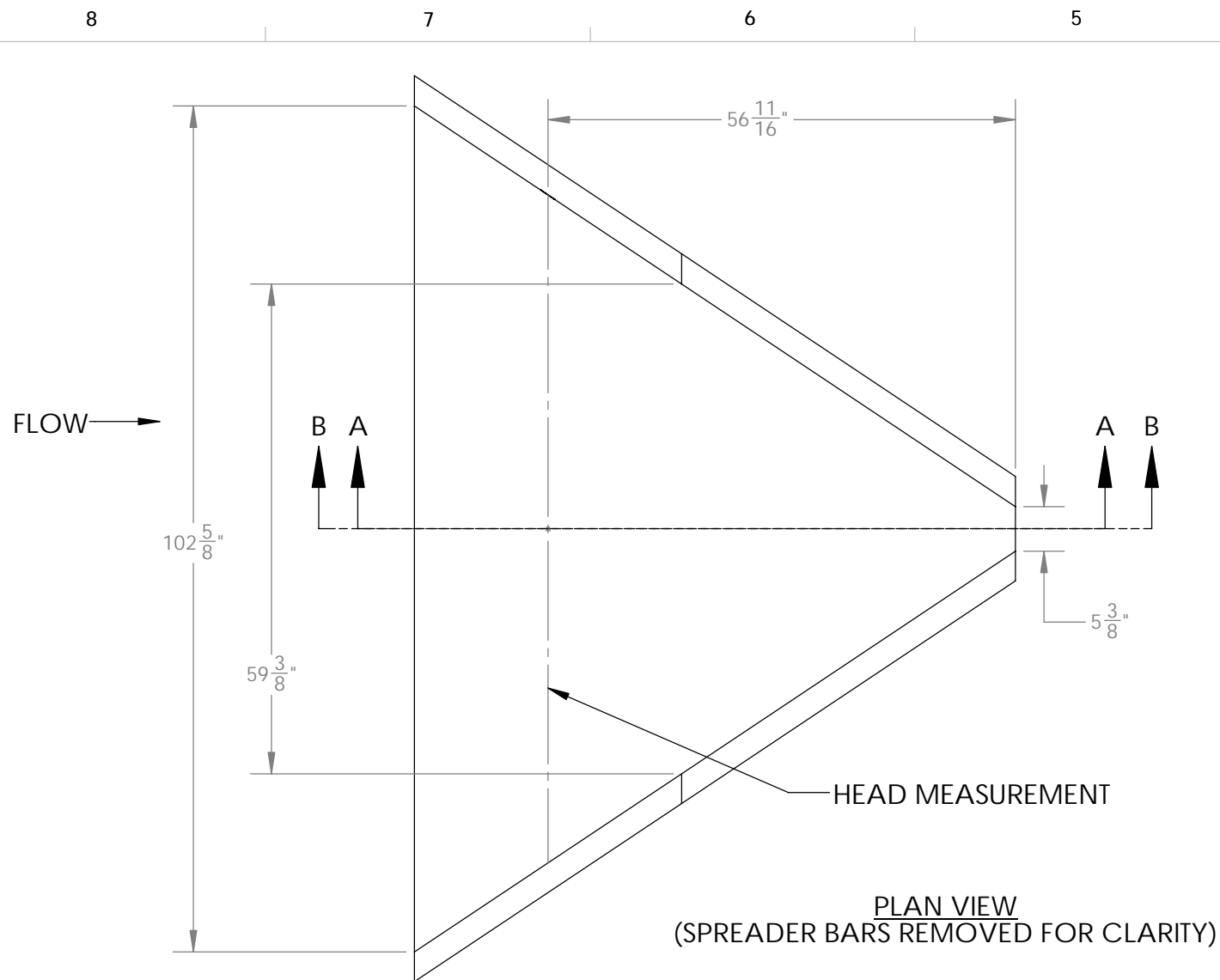

PROPRIETARY AND CONFIDENTIAL
THE INFORMATION CONTAINED IN THIS
DRAWING IS THE SOLE PROPERTY OF
Virtual Polymer Compounds, LLC. ANY
REPRODUCTION IN PART OR AS A WHOLE
WITHOUT THE WRITTEN PERMISSION OF
Virtual Polymer Compounds, LLC IS
PROHIBITED.

UNLESS OTHERWISE SPECIFIED:
DIMENSIONS ARE IN INCHES
TOLERANCES:
FRACTIONAL ±
ANGULAR: MACH ± BEND ±
TWO PLACE DECIMAL ±
THREE PLACE DECIMAL ±

INTERPRET GEOMETRIC
TOLERANCING PER:
MATERIAL
POLYESTER RESIN
FINISH

DO NOT SCALE DRAWING

	NAME	DATE
DRAWN	LVR	9/4/2020
CHECKED		
ENG APPR.		
MFG APPR.		
Q.A.		
COMMENTS:		
3rd ANGLE PROJECTION		

		10478 Ridge Rd., Medina NY 14103 Toll Free: 888-290-9522 Phone: 585-735-9668	
TITLE: 4.5H FLUME			
Project: NO OPTIONS			
SIZE B	DWG. NO.	REV A	
SCALE: 1:20	Weight 172.88	SHEET 3 OF 5	

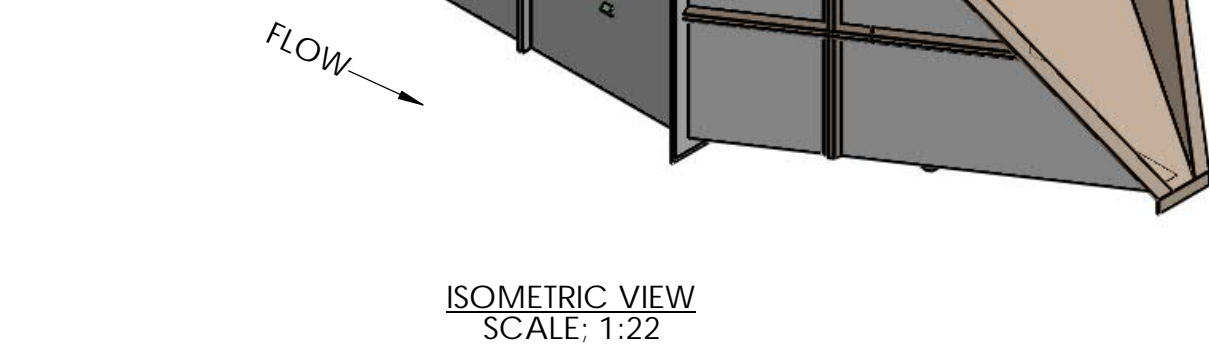
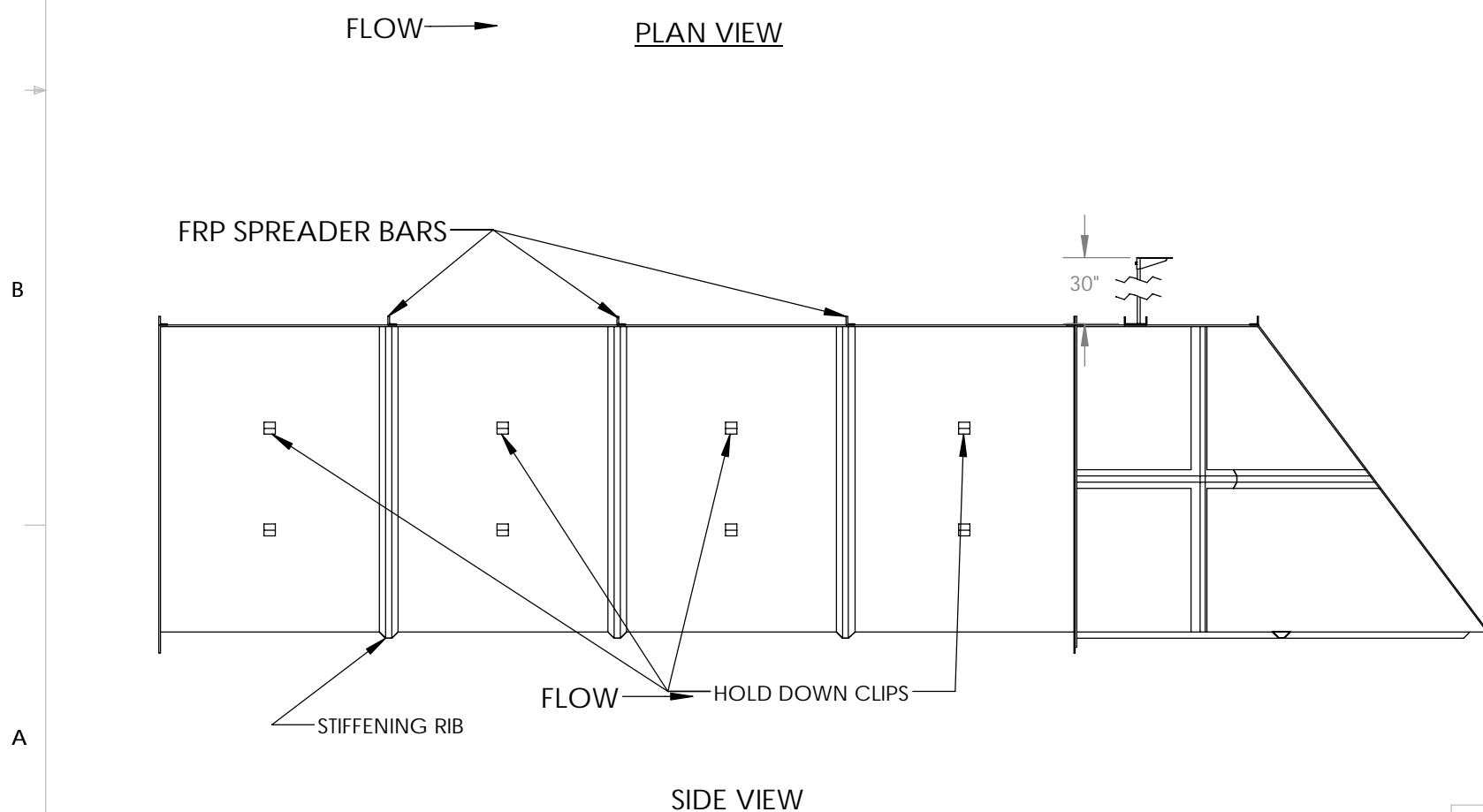
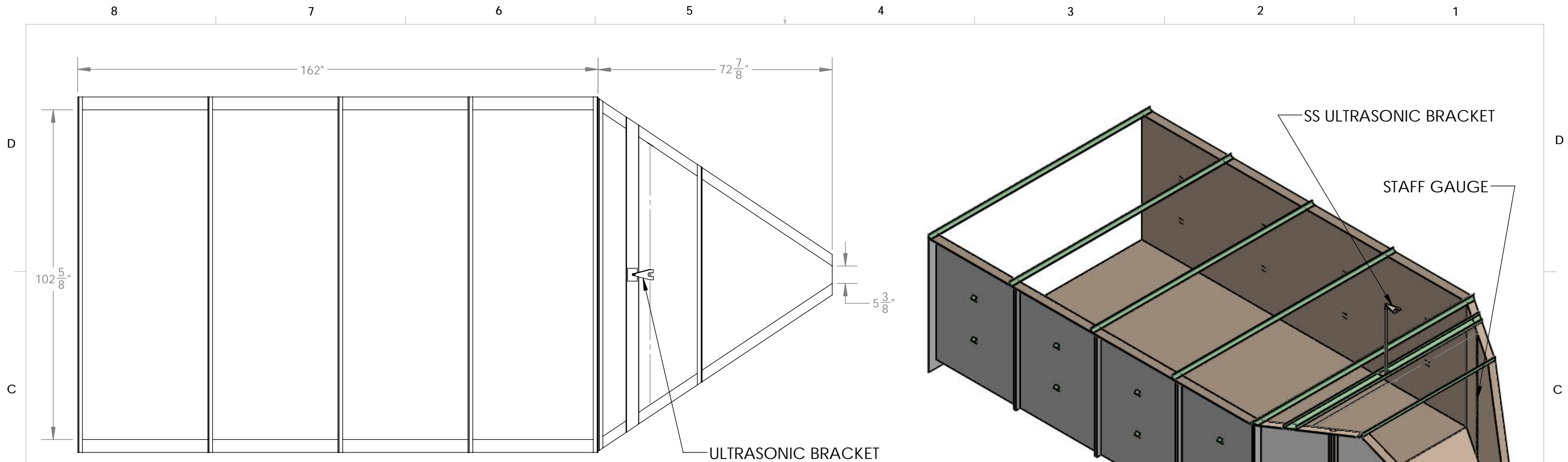

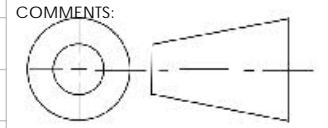
UNLESS OTHERWISE SPECIFIED:		NAME	DATE	 VPC 10478 Ridge Rd., Medina NY 14103 Toll Free: 888-290-9522 Phone: 585-735-9668
DIMENSIONS ARE IN INCHES TOLERANCES: FRACTIONAL ± ANGULAR: MACH ± BEND ± TWO PLACE DECIMAL ± THREE PLACE DECIMAL ±		DRAWN	LVR 9/4/2020	
INTERPRET GEOMETRIC TOLERANCING PER:		CHECKED		TITLE: 4.5H FLUME
MATERIAL POLYESTER RESIN FINISH		ENG APPR.		Project: WITH OPTIONS
DO NOT SCALE DRAWING		MFG APPR.		SIZE DWG. NO. REV B
PROPRIETARY AND CONFIDENTIAL THE INFORMATION CONTAINED IN THIS DRAWING IS THE SOLE PROPERTY OF Virtual Polymer Compounds, LLC. ANY REPRODUCTION IN PART OR AS A WHOLE WITHOUT THE WRITTEN PERMISSION OF Virtual Polymer Compounds, LLC IS PROHIBITED.		Q.A.		SCALE: 1:30 Weight 695.39 SHEET 4 OF 5
		COMMENTS:	 3rd ANGLE PROJECTION	

8 7 6 5 4 3 2 1

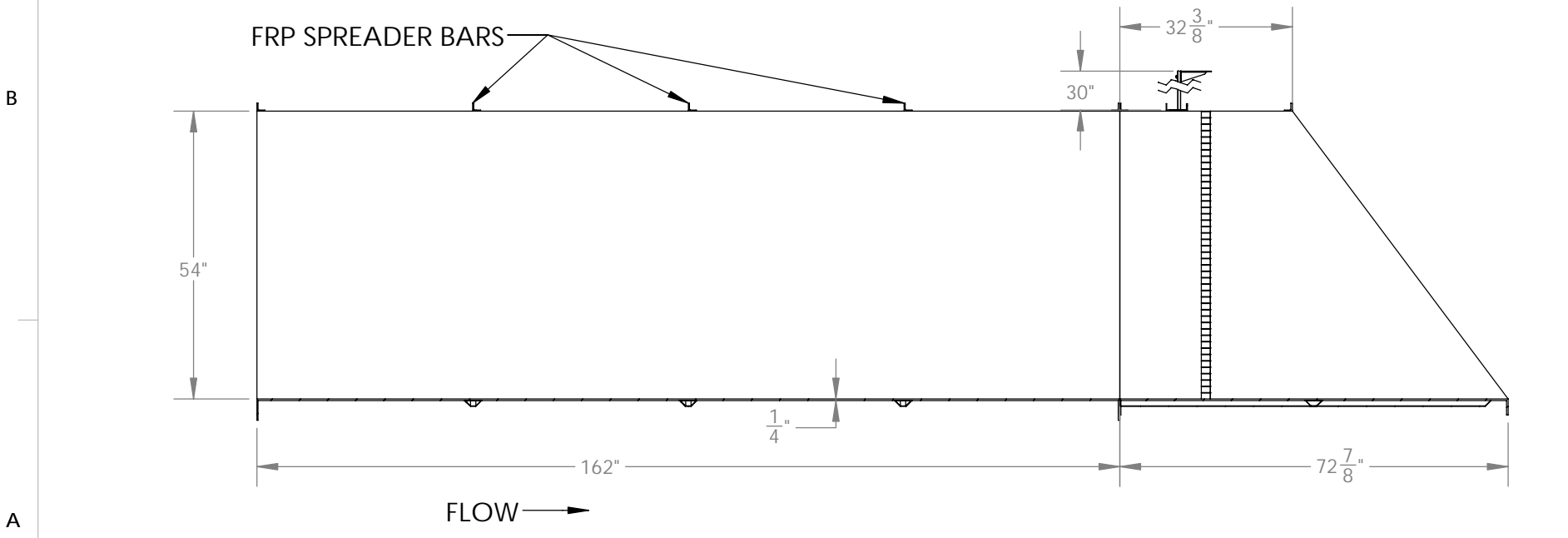
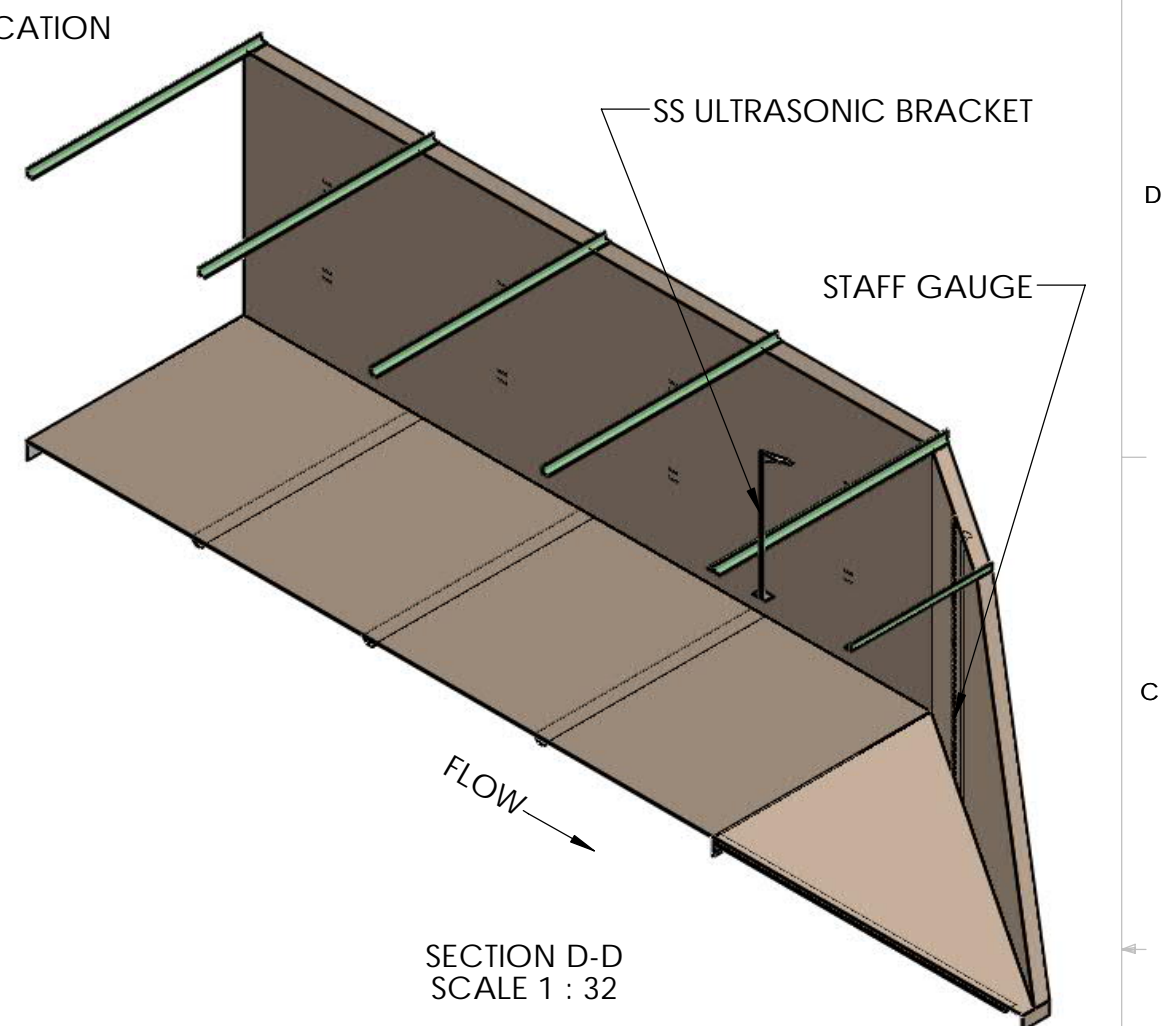
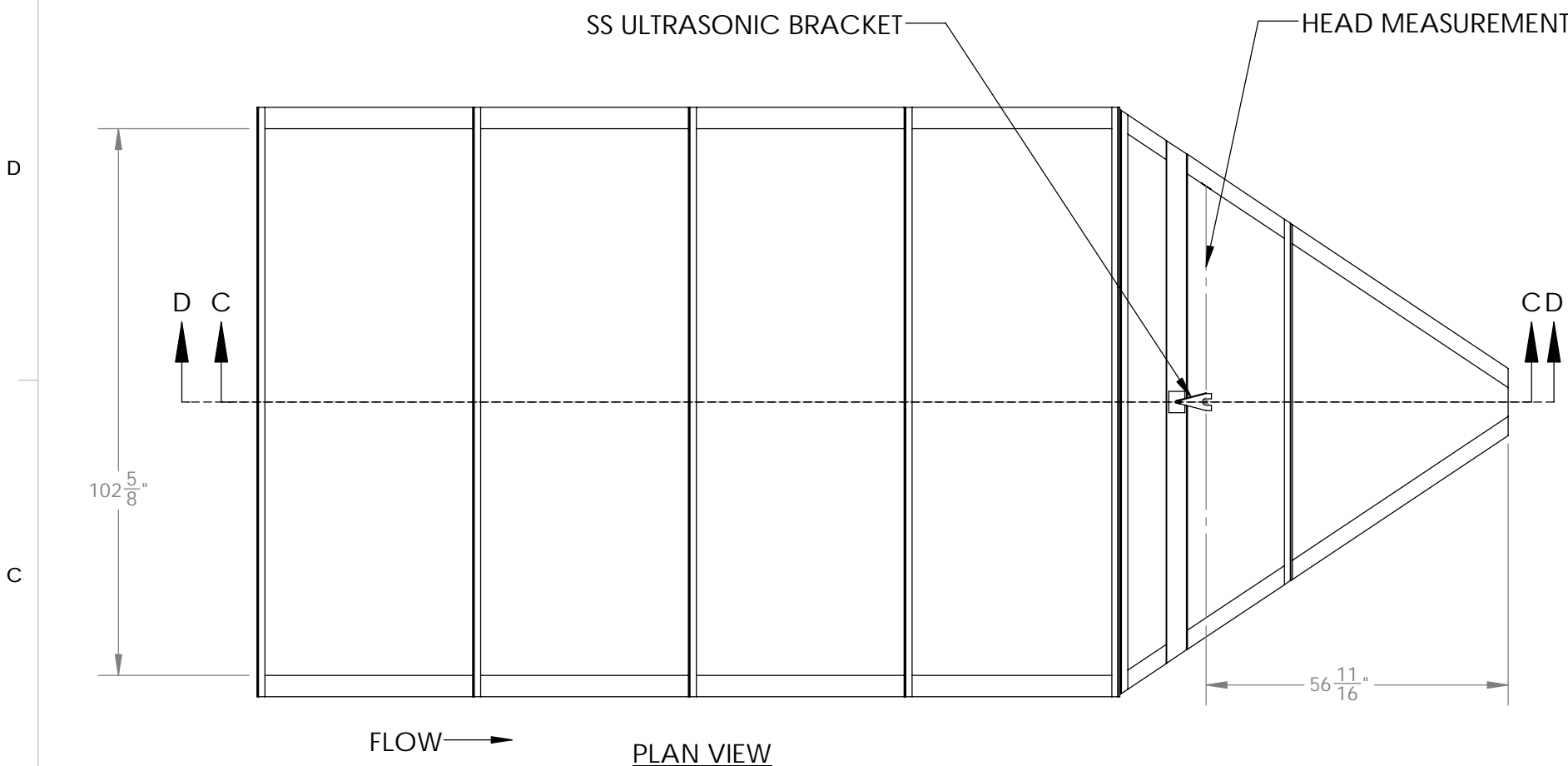

UNLESS OTHERWISE SPECIFIED:		NAME	DATE	 VPC 10478 Ridge Rd., Medina NY 14103 Toll Free: 888-290-9522 Phone: 585-735-9668		
DIMENSIONS ARE IN INCHES TOLERANCES: FRACTIONAL ± ANGULAR: MACH ± BEND ± TWO PLACE DECIMAL ± THREE PLACE DECIMAL ±		DRAWN	LVR 9/4/2020			
INTERPRET GEOMETRIC TOLERANCING PER:		CHECKED		TITLE:	4.5H FLUME	
MATERIAL POLYESTER RESIN FINISH		ENG APPR.		Project:	WITH OPTIONS	
DO NOT SCALE DRAWING		MFG APPR.		SIZE	DWG. NO.	REV
3rd ANGLE PROJECTION		Q.A.		B		A
		COMMENTS:		SCALE: 1:30	Weight 695.39	SHEET 5 OF 5

PROPRIETARY AND CONFIDENTIAL
 THE INFORMATION CONTAINED IN THIS
 DRAWING IS THE SOLE PROPERTY OF
 Virtual Polymer Compounds, LLC. ANY
 REPRODUCTION IN PART OR AS A WHOLE
 WITHOUT THE WRITTEN PERMISSION OF
 Virtual Polymer Compounds, LLC IS
 PROHIBITED.

8 7 6 5 4 3 2 1