

8

7

6

5

4

3

2

1

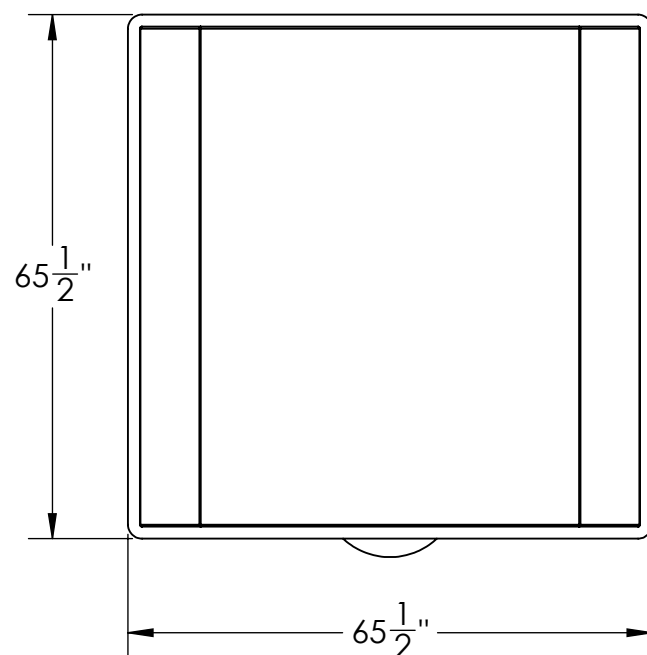

NOTES:

- VINYL ESTER RESIN CONSTRUCTION
- 316SS HARDWARE AND SHAFT
- V-BELT DRIVE
- EPDM SHAFT SEAL
- UV INHIBITOR ON EXTERIOR
- C-VEIL ON AIRSTREAM
- STD GRAY EXTERIOR

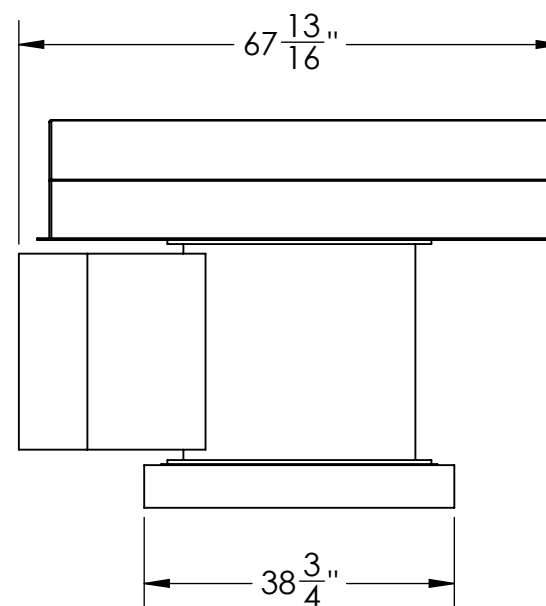
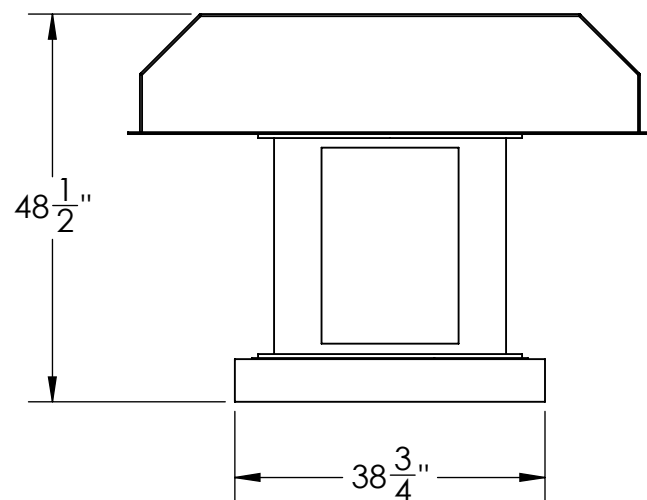
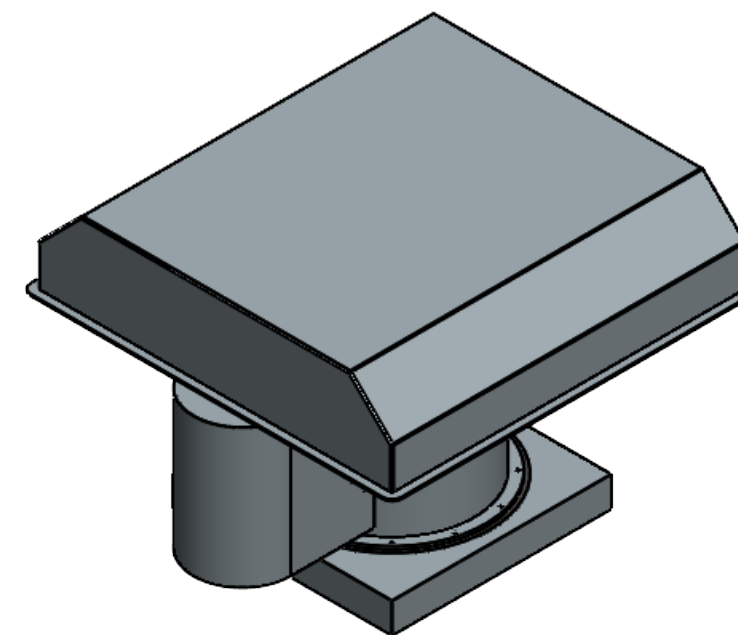

PROPRIETARY AND CONFIDENTIAL
 THE INFORMATION CONTAINED IN THIS DRAWING IS THE SOLE PROPERTY OF VIRTUAL POLYMER COMPOUNDS. ANY REPRODUCTION IN PART OR AS A WHOLE WITHOUT THE WRITTEN PERMISSION OF VIRTUAL POLYMER COMPOUNDS IS PROHIBITED.

		UNLESS OTHERWISE SPECIFIED:	NAME	DATE
		DIMENSIONS ARE IN INCHES	DRAWN	CD
		TOLERANCES:	CHECKED	---
		FRACTIONAL ±	ENG APPR.	---
		ANGULAR: MACH ± BEND ±	MFG APPR.	---
		TWO PLACE DECIMAL ±	Q.A.	---
		THREE PLACE DECIMAL ±	COMMENTS:	
NEXT ASSY	USED ON	INTERPRET GEOMETRIC TOLERANCING PER:		
		MATERIAL:		
		FINISH:		
APPLICATION		DO NOT SCALE DRAWING		

CFT COMPOSITE FAN TECHNOLOGY

TITLE:
28 TAHD GENERAL ASSEMBLY DRAWING

SIZE	DWG. NO.	REV
B		-
SCALE:	WEIGHT:	SHEET 1 OF 2

8

7

6

5

4

3

2

1

F

E

D

C

B

A

F

E

D

C

B

A

ITEM NO.	DESCRIPTION	ITEM NO.	DESCRIPTION
1	HOUSING	12	UPPER COVER GASKET
2	ROOF CURB	13	LOWER COVER GASKET
3	ROOF CURB GASKET	14	BEARING
4	WEATHER COVER	15	SHAFT SEAL
5	HOOD	16	SHAFT SEAL PLATE
6	WHEEL	17	SHAFT BUSHING
7	MOTOR PLATE	18	SHAFT SHEAVE
8	MOTOR	19	DRIVE BUSHING
9	SHAFT	20	DRIVE SHEAVE
10	UPPER BEARING COVER	21	BELTS
11	LOWER BEARING COVER		

		UNLESS OTHERWISE SPECIFIED:		NAME	DATE	CFT COMPOSITE FAN TECHNOLOGY
		DIMENSIONS ARE IN INCHES TOLERANCES: FRACTIONAL ± ANGULAR: MACH ± BEND ± TWO PLACE DECIMAL ± THREE PLACE DECIMAL ±		DRAWN	CD	
				CHECKED	---	TITLE:
				ENG APPR.	---	28 TAHD GENERAL ASSEMBLY DRAWING
				MFG APPR.	---	
				Q.A.	---	SIZE
				COMMENTS:		DWG. NO.
						REV
						-
NEXT ASSY	USED ON					SCALE:
APPLICATION		DO NOT SCALE DRAWING				WEIGHT:
						SHEET 2 OF 2

PROPRIETARY AND CONFIDENTIAL
THE INFORMATION CONTAINED IN THIS DRAWING IS THE SOLE PROPERTY OF VIRTUAL POLYMER COMPOUNDS. ANY REPRODUCTION IN PART OR AS A WHOLE WITHOUT THE WRITTEN PERMISSION OF VIRTUAL POLYMER COMPOUNDS IS PROHIBITED.

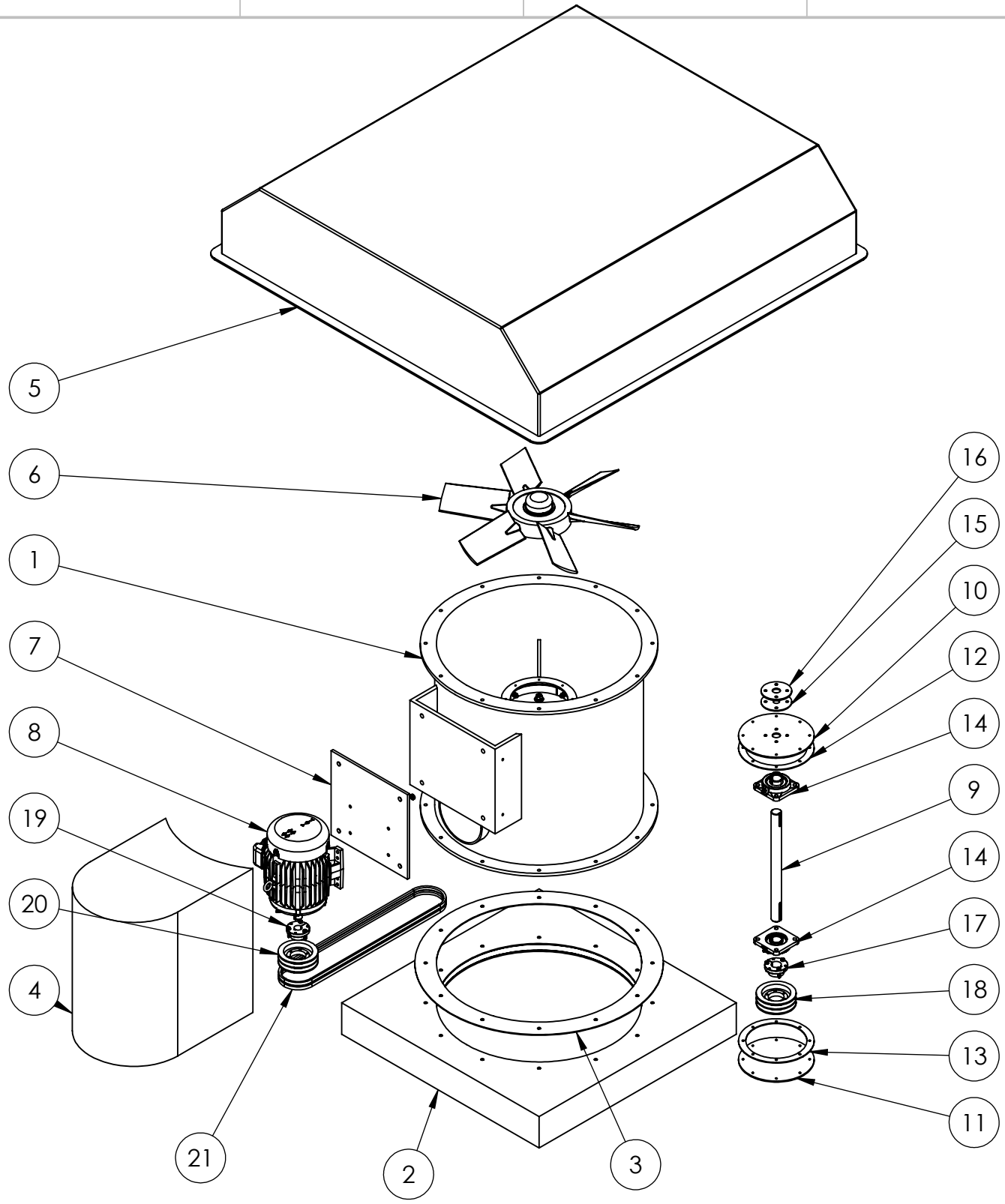

8 7 6 5 4 3 2 1

F
E
D
C
B
A

F
E
D
C
B
A

8 7 6 5 4 3 2 1